



Study of Automatic Gain Control System in Broadband Radio Receiver

Kh. Kh. Hashimov ^{a*}

^a Azerbaijan State Oil and Industry University, Baku, Azerbaijan.

Author's contribution

The sole author designed, analyzed, interpreted and prepared the manuscript

Article Information

DOI: 10.9734/JERR/2023/v25i7937

Open Peer Review History:

This journal follows the Advanced Open Peer Review policy. Identity of the Reviewers, Editor(s) and additional Reviewers, peer review comments, different versions of the manuscript, comments of the editors, etc are available here: <https://www.sdiarticle5.com/review-history/103367>

Original Research Article

Received: 19/05/2023

Accepted: 21/07/2023

Published: 28/07/2023

ABSTRACT

In modern times, almost all communication systems are digital. In the receivers of such communication systems, the analog signal is discretized and quantized using an analog-to-digital converter at an intermediate frequency. Automatic gain control is used to avoid overloading the analog-to-digital converter and to maintain intermediate frequency analog signals at a suitable fixed level. If the power of the received signals is much less than the load level of the analog-to-digital converter, the automatic gain adjustment increases the gain, reducing the quantization noise. If the received signal strength is high, the automatic gain adjustment lowers the gain so that the analog-to-digital converter is not overloaded. The accuracy of the adjustment of the transmission coefficient of the automatic adjustment of the digital amplification does not always satisfy the requirements given in real time. Based on the above, the article is devoted to the study of the digital automatic gain regulator of the broadband radio receiver.

Keywords: Regulation; broadband; harmonic; signal; digital; receiver.

*Corresponding author: Email: heshimov.x@mail.ru;

1. INTRODUCTION

The development of broadband communication was served by the development of cheap and not very large logic integrated circuits. This type of integrated circuits allows the transition of broadband signal processing from analog to digital, increasing the stability and linearity of the channels, increasing the diversity of channels and simplifying the filtering. The use of digital signal processors and programmable logic integrated circuits during the implementation of the digital signal processing algorithm made it possible to reduce the size and mass of the device and significantly increase its reliability. Automatic power regulation plays an important role in modern transceivers for GPS, WLAN, Bluetooth, ZigBee, GSM analog and digital communication systems [1-17].

In order to ensure a fast response of the automatic gain adjustment system of the broadband receiver to the change in the signal strength at the input, it is necessary to adjust the parameters of the automatic gain adjustment under changing electromagnetic conditions.

The input of a wideband receiver is affected by some random process, which we consider in general as the broadcast of narrowband independent signals of unknown intensity $\xi(t)$ on a background of normal white noise:

$$U_{\text{intro}}(t) = \xi(t) + \sum_{i=1}^M V_i(t) \cdot \sin(2\pi f_{oi}t + \theta_i t), \quad (1)$$

Here, $V_i(t)$ and $\theta_i(t)$ are the starting phase of the i -th narrowband signal, f_{oi} is the carrier frequency of the i -th signal, is the number of M -band signals.

At times, the number of components is uncertain. There is also no a priori information about the parameters of frequency modulation.

Each component of expression (1) can be viewed as a random normal process with zero mean $\overline{U_{\text{output}}}(t) = 0$ and some $\overline{U_{\text{output}}}$ even that each component of the expression is approximately the same.

If there are dominances between M components due to separate power, then the properties of stationarity and normality of the random process are violated. Then that unit can be given as the sum of the sum of the strong components and the rest of the other waves.

The problem of estimation of input signal parameters can be put as follows. Let's assume that the wave voltage $U_{\text{entry}}(t)$ in the accepted time interval $(0, T)$ consists of the unknown parameter A (in our case A is the amplitude of the signal) and the sum of the signal $S(t, A)$ which is smoothed from white noise:

$$U_{\text{intro}}(t) = s(t, A) + \xi(t), \quad 0 \leq t \leq T \quad (2)$$

The signal $S(t, A)$ consists of several harmonic signals of amplitude A and $\xi(t) = 0$, the following equation is true:

$$U_{\text{Intro}}(t) = A \cdot \sin(2\pi f_0 t), \quad (3)$$

Here, A is the amplitude of the signal, f_0 is the frequency of the signal. As can be seen from Fig. 1., the reference signal R is compared with the modulus of the instantaneous value of the output signal. Then the wrong amount is rounded in the filter. Then, if we put the module (3) in the Fourier series, we get the value of the constant component $c = \frac{2}{\pi} = 0,636$ Thus, the normalized value of the support signal should be 0.636.

2. SOLVING THE PROBLEM

Assume that the input of the system includes harmonic signal $S(t)$ and additive normal white noise $\xi(t)$. Fig. 1., it is shown that the quantity $\frac{|U_{\text{Intro}}(t)|}{(U_{\text{Intro max}}(t))} = R_{\text{opposite}}$ depends on different values of the signal/noise ratio.

As can be seen in Fig. 1., when the value of the signal-to-noise ratio is less than 30dB , the accumulation of the additive noise component starts to rise suddenly, which causes the required reference value R_{opposite} to deviate from the reference value R . As a result, it is necessary to adaptively set the digital system of automatic gain adjustment (R_{opposite}) support level in order to prevent the tract from being reloaded during the operation of the system if the noise level in the input signal increases [12-16].

Let's consider the case where the input of the system consists of 2 harmonic components of different amplitude and frequency.

$$U_{\text{Intro}}(A, f, t) = \frac{A_{\text{max}}}{2} \sin(2\pi f_{\text{min}} t) + A \cdot \sin(2\pi f t), \quad (4)$$

Here, $A = (0; A_{\text{max}})$, $f = (f_{\text{min}}; f_{\text{max}})$.

As you can see, formula (4) can be written in another form [17]:

$$\begin{aligned} & A\sin(\omega t + \varphi) + B\sin(\omega t) \\ &= \sqrt{A^2 + B^2 + 2AB\cos(\varphi)} \cdot \\ & \sin\left(\omega t + \tan^{-1} \frac{A\sin\varphi}{A\cos\varphi + B}\right) \end{aligned} \quad (5)$$

It can be seen from the expression (5) that the main signal will be the sum amplitude and will depend on the amplitude of both signals. If we consider expression (5), we get;

$$\begin{aligned} & \frac{A_{max}}{2} \sin(2\pi f_{min}t) + A \cdot \sin(2\pi ft) = \\ & \lambda \sin(\omega t) + \varphi, \end{aligned} \quad (6)$$

Here, $\lambda = \sqrt{\left(\frac{A_{max}}{2}\right)^2 + A^2 + A \cdot A_{max} \cos\delta}$ is the sum amplitude.

$$\begin{aligned} \varphi = \tan^{-1} \frac{A_{max} \sin(\delta)/2}{(A_{max} \cos(\delta)/2) + A} \quad \text{phase,} \quad \delta = \\ 2\pi f_{min}t - 2\pi ft \text{ is the phase difference.} \end{aligned}$$

Then, the reference level quantity should correspond to the constant component quantity regardless of the signal amplitude, or rather,

$$R = \frac{|U_{output}(t)|}{\lambda}$$

Fig. 2. shows the dependence of the required reference signal quantity R on the amplitude of the II harmonic signal during the input effect described by the expression (4). Meanwhile, the amplitude and frequency of the first signal are constant and equal to $\frac{A_{max}}{2} = \frac{1}{2} = 0,5$ and $f_{min} = 4MHz$. The frequency of the second signal is $f = 7,5MHz$

As can be seen from Fig. 2, the change in the signal strength at the input of the digital system of the automatic gain adjustment is $\Delta R = 30\%$ during the 2-signal effect. The maximum value of the power occurs when the I and II harmonic signal is equal.

The input of the broadband receiver is affected by the signal (1). Let's consider the case where a signal consisting of M harmonic components of the same amplitude and equally distributed over the spectrum is given to the input of the digital system of automatic gain control. Let's look at the dependence of the required support level relative to the harmonic components in the input signal (Fig. 3.).

As can be seen from Fig. 3., when there is a large amount of components ($M > 6$) in the input signal, the dependence of the required reference signal $R_{opposite}$ on the amount of M components decreases. ($M > 15R_{opposite}$) is located near the value of 0.1. Thus, the accumulation of each component decreases with the increase in their prices. The value of the required reference signal $R_{opposite}$ has a hyperbolic dependence on M .

Apparently, the evaluation of the signal occurs after the analog-to-digital converter block, that is, when a signal with a bias level greater than $U_{pp}/2$ is applied to the input, which leads to a converter reload.

When the bias of the input signal $U_{pp}2V$, it becomes a maximum value, which indicates that the calculated value for the R -reference signal is incorrect.

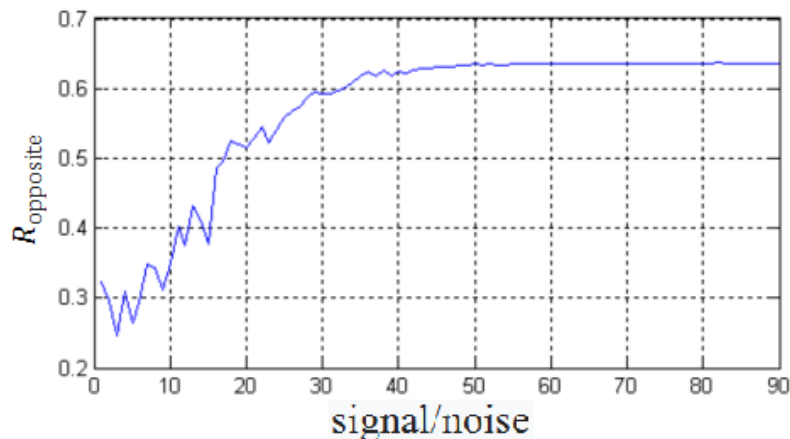

Fig. 1. Dependence of $R_{opposite}$ on the signal-to-noise ratio

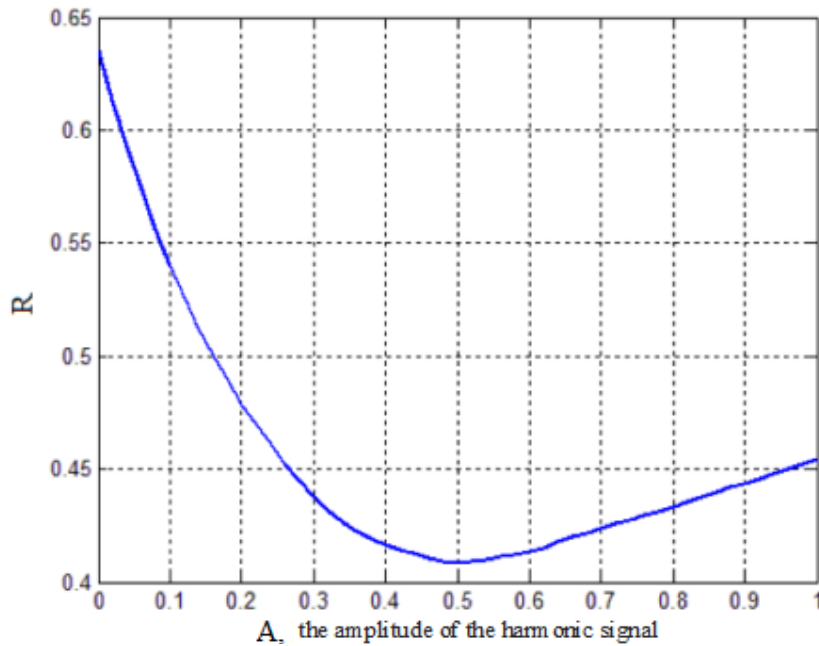

Fig. 2. The amplitude of the II harmonic signal during the 2-signal effect of the required support level

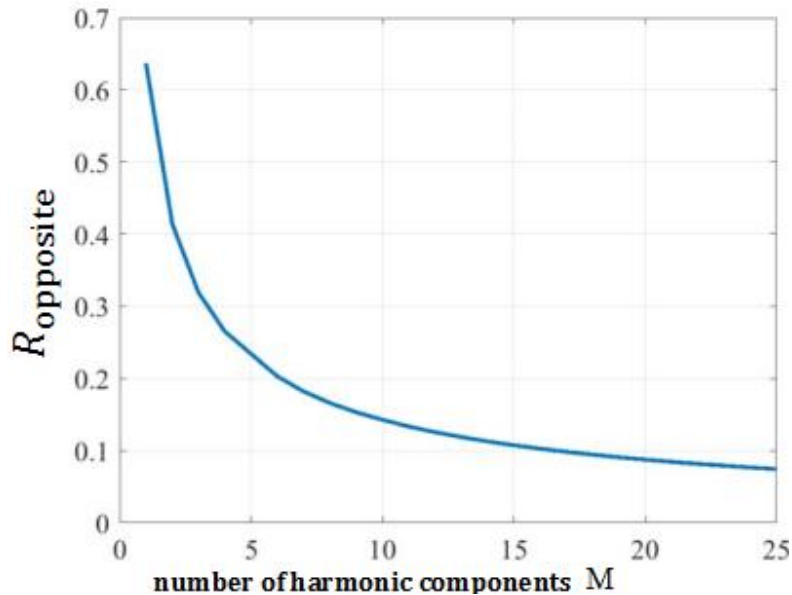

Fig. 3. Dependence of the required support level $R_{opposite}$ on the number of harmonic components

Thus, in order to ensure more accurate operation of the indicated automatic gain adjustment system, it is necessary to add a reference signal building block to the given circuit, which will evaluate the change in signal strength caused by the change in electromagnetic conditions, not by the signal fading.

Fig. 4. shows the structural diagram of the digital model of the automatic adjustment of the hybrid power amplifier. This block consists of a power detector and a switch. In which ($R = 0,1$) the value of the reference signal calculated at its minimum value changes. Switching is performed when the reference signal level exceeds the calculated value $R_{max} = 0,636$.

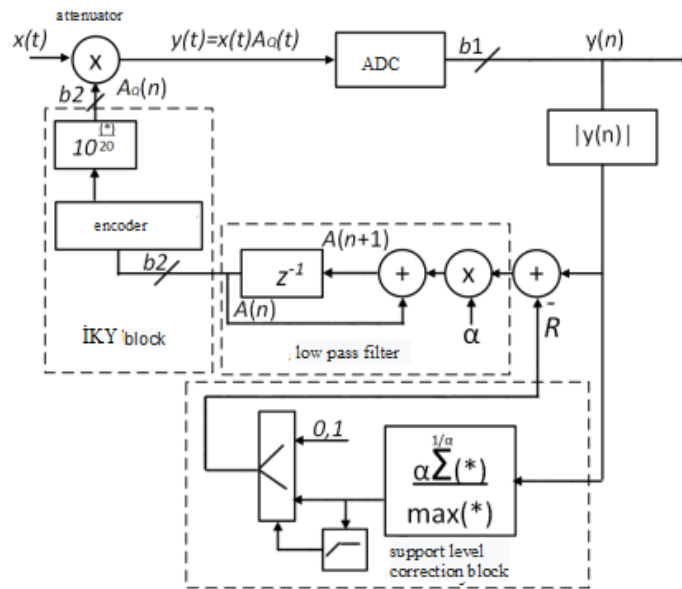

Fig. 4. Structural diagram of the digital model of the automatic regulation system of the hybrid boost with the support level correction block

3. CONCLUSION

Thus, the importance of establishing the support level of the automatic gain adjustment system under the influence of a complex of harmonic signals at its input is shown. The establishment of a reference level during the influence of a complex of harmonic signals leads to a reduction in the error in the adjustment and allows to reduce the adjustment time of the automatic gain adjustment system during the time of loading the tract with strong obstacles and the analog digital converter during floor loading.

COMPETING INTERESTS

Author has declared that no competing interests exist.

REFERENCES

1. Ben-Romdhane M. Nonuniformly controlled analog-to-digital converter for SDR multistandard radio receiver / M.Ben-Romdhane, C. Rebai, A. Ghazel, P.Desgreys, P. Loumeau // IEEE Trans. Circuits Syst. II Express Briefs. 2011; 58(12):862-866.
2. Matveev SE, KofanovYu N, Roizman VP. Methods for system analysis of vibration strength of products. - M.: Radio and communications. 2002;178.

3. Alegre JP. A high performance CMOS feedforward AGC circuit for wideband wireless receivers / J.P.Alegre, B.Calvo, S.Celma // IEEE International Symposium on Industrial Electronics, Cambridge. 2008;1657-1661.
4. Kh. Kh. Hashimov. Investigation of crystal structure and polymorphic transformations of Cu-S system compounds. V International Scientific and Practical Conference «Modern science:actual problems», Manchester. 2023;56-60.
5. Islamov IJ, Shukurov NM, Abdullayev R.Sh. Hashimov, Kh.Kh. Khalilov AI. Diffraction of electromagnetic waves of rectangular waveguides with a longitudinal. In: IEEE Conferences 2020 Wave Electronics and its Application in Information and Telecommunication.
6. Islamov IJ, Mammadov EA, Rustamov AR, Kh. Kh. Hashimov H, Sh. Nabiyev AI. Simulation of an antenna device with frequency scanning international symposium for production research, SCOPUS, Science Citation Index Expanded, IEEE, Springer Antalya. 2022; 594-606.
7. Gochuyeva AF, Kh. Kh. Hashimov, Bayramov IY. Photoelectret effect in polymer-AIBVI (CdS, ZnS) composites of photosensitive semiconductors / Chalcogenide Letters. 2023;20(4): 285-291.

- Available:<https://doi.org/10.15251/CL.2023.204.285>
8. Kh. Kh. Hashimov. Investigation of crystal structure and polymorphic transformations of Cu-S system compounds/ V International Scientific and Practical Conference «Modern science: Actual problems», May 16-17, 2023, Manchester. UK. 2023;66:56-60. ISBN 978-91-65423-19-0.
DOI:<https://doi.org/10.5281/zenodo.7950997>.
 9. Kh. Kh. Hashimov, Mammadov ES. Application of solid-state filters in radio reconnaissance receivers / Scientific works of Azerbaijan Technical University, Baku. 2019;2:101-104, ISSN 1815-1779
 10. Kh. Kh. Hashimov, Mammadov ES. Calculation of quasi-statistical potential diagrams in load-coupled devices Scientific works of Azerbaijan Technical University, Baku. 2019;4:16-18. ISSN 1815-1779.
 11. Kh. Kh. Hashimov, Jahangirov MM. Development of monolithic integrated circuits with built-in antenna in the high frequency range / Azerbaijan National Academy of Sciences, "Young Researcher" Scientific-practical Journal, Baku. 2020;2:8-13. ISSN 2409-4838.
URL:https://gencalimler.az/uploads/Genc_Tedqiqatci_2020_N2_SON.pdf
 12. Prasolov AA. Digital AGC reference level correction in a wideband quadrature amplitude modulated radio receiver. 2019;13, , T-Comm, №7:54–59.
 13. Prasolov AA. Modeling of digital AGC With multi-signal impact and adaptation of the reference level / Electronic and Networking Technologies (MWENT), Moscow Workshop on, IEEE. 2018;1–4.
 14. Liu J, Xie J, Zhang X, Wang J. "Jammer localization approach based on crowdsourcing carrier-to-noise density power ratio fusion," in Proc. China Satellite Navigation Conference (CSNC), Chengdu, China. 2020;604–612.
 15. Kaltiokallio M, Valkonen R, Stadius K, Ryyanen J. A 0.7-2.7GHz blocker-tolerant compact-size single-antenna receiver for wideband mobile applications, IEEE Trans. Microw. Theory Techn. 2013;61:3339-3349,.
 16. Huang L, Russer P. Electrically tunable antenna design procedure for mobile applications, IEEE Trans. Microw. Theory Techn. 2008;56:2789 -2797.
 17. Brand S. QAM Demodulation [Electronic resource] / PhilipsSemiconductors, Wirel. Commun.
URL:<http://www.wirelesscommunication.nl/reference/pdfandps/qam.pdf>

© 2023 Hashimov; This is an Open Access article distributed under the terms of the Creative Commons Attribution License (<http://creativecommons.org/licenses/by/4.0>), which permits unrestricted use, distribution, and reproduction in any medium, provided the original work is properly cited.

Peer-review history:

*The peer review history for this paper can be accessed here:
<https://www.sdiarticle5.com/review-history/103367>*