



Techno-Economic Analysis of a Hybrid Mini-grid in Rural Areas: A Case Study of Bangladesh

Tausif Ali^{1*}, Hongzhong Ma¹ and Ahmed Jaudat Nahian²

¹College of Energy and Electrical Engineering, Hohai University, Nanjing 211100, China.

²Department of Electrical and Electronic Engineering, Faculty of Science Engineering and Technology, Bangladesh University, 15/1 Iqbal Road, Mohammadpur, Dhaka - 1207, Bangladesh.

Authors' contributions

This work was carried out in collaboration among all authors. Author TA designed the study, performed the simulation, wrote the protocol and wrote the first draft of the manuscript. Authors HM and AJN managed the proofreading and provided valuable advice to improve the study. All authors read and approved the final manuscript.

Article Information

DOI: 10.9734/JENRR/2020/v4i130116

Editor(s):

(1) Dr. Huan-Liang Tsai, Professor, Department of Electric Engineering, Da-Yeh University, Taiwan.

Reviewers:

(1) Alessandro Burgio, University of Calabria, Italy.

(2) Aysar M. Yasin, An-Najah National University, Israel.

Complete Peer review History: <http://www.sdiarticle4.com/review-history/53973>

Original Research Article

Received 05 November 2019

Accepted 10 January 2020

Published 16 January 2020

ABSTRACT

A techno-economic analysis of a hybrid PV-Diesel mini-grid system in rural Bangladesh is presented in this study. The case-study is done using data from Patar Char village in Patuakhali district of Bangladesh, considering non-electrified households. HOMER simulation compares three system designs: Hybrid PV-Diesel-Battery, PV-Battery, and Diesel-Battery. Hybrid PV-Diesel-Battery system yielded optimum results in terms of the lower cost of energy (COE) of around USD 0.182/kWh. Overall carbon emission of this system is around 307 kg/year, which is lower than the Diesel-Battery system, but higher than PV-Battery system. A sensitivity analysis of PV-Diesel-Battery system is performed, by considering and varying some of the indicators to prove system sustainability and feasibility. The impact of price variability in diesel price, discount rate on COE, and total net present cost (TNPC) showed that PV-Diesel-Battery system is the most feasible option. Finally, a SWOT analysis is also presented to address participatory planning strategy of developing the hybrid energy system.

*Corresponding author: E-mail: tausif.ali@hhu.edu.cn;

Keywords: Renewable energy; hybrid energy system; mini-grid; rural Bangladesh; optimization; HOMER.

1. INTRODUCTION

In developing countries like Bangladesh, the bulk of electricity is generated from fossil fuels (coal, oil, and natural gas). Fossil fuel based traditional power generation is harmful to the environment because of greenhouse gas (GHG) emissions. Many environmental organizations have made their concern about the harmfulness of conventional power generation. However, the increasing need for electricity, in Bangladesh, cannot be met with the remaining reserves of coal, oil, and gas; these fuel sources will deplete soon. New energy sources are required to be explored and included in the energy mix of the country. Besides the energy crisis, centralized generation units do not have the capability and infrastructure to reach remote areas. Thus, many villages are still not electrified. Sustainable development is hindered due to inaccessibility of electricity. Initiatives are required in those areas where the main grid will not be able to reach shortly. Decentralized generation using renewable energy sources can be a viable option considering the energy need, depletion and high price of fossil fuels, and climate and environmental issues. However, the techno-economic feasibility of off-grid solutions needs to be analysed with comparison to the main grid. Also, the reliability and continuous operation of the grid must be ensured. Renewable sources (e.g., solar and wind) have limitations in stable and continuous electricity supply due to their intermittent behaviour. Per unit cost (USD/kWh) of electricity from solar is still higher than fossil fuels. Solar modules and wind generators can only be placed at specific locations where there are ample solar irradiation and considerable wind speed, respectively. Battery systems may need to be integrated, to store the excess energy from solar and wind, to be used at times of peak demand. Diesel generators have been used over

the years to strengthen the decentralized hybrid mini-grids. Although diesel generators are not the best option for its high CO₂ emission, the economy and investment behind the generators are far better than developing only renewable sources-based generation. A techno-economic and environmental case study between the available renewable sources, in combination with diesel generators, is needed to find the balance between the economy, environment, and the electricity demand.

The Infrastructure Development Company Limited (IDCOL) has approved 16 Solar Mini-Grid Projects, among which seven are operational while the rest are under construction. The company has targeted to install 50 solar mini-grids by 2018, approved 459 solar irrigation pumps, of which 324 are already in operation [1]. According to IDCOL, the mini-grid project has successfully created access to low-emission electricity for almost 5,000 rural households in Bangladesh. Bangladesh Power Development Board (BPDB) has installed 900 kW capacity grid connected Wind Plant at Muhuri Dam area of Sonagazi in Feni. Another project of 1,000 kW Wind-Battery Hybrid energy system at Kutubdia Island was ended by BPDB in 2008 which consists of 50 Wind Turbines of 20 kW capacities each. At present BPDB is executing 7.5 MW off-grid hybrid project with a combination of Wind, Solar and HFO/Diesel based engine-driven generator in Hatiya Island, Noakhali. The organization has also planned to construct 1 MW off-grid Solar-Diesel hybrid power plant project in Kutubdia Island. Apart from that, IDCOL has financed nine bio-gas based power plants, having a total capacity of 618 kW and two rice-husk based power plants having a total capacity of 650 kW in the country. From Table 1 and Table 2 it is evident that the installed capacity of off-grid hybrid energy systems is low.

Table 1. Installed renewable energy technologies in Bangladesh [2]

Technology	Off-Grid (MW)	On-Grid (MW)	Total (MW)
Biogas to electricity	5	-	5
Biomass to electricity	1	-	1
Hydro	-	230	230
Solar PV	184	1	185
Wind	1	0.9	1.9
Total	191	232	423

Table 2. Wind turbine installations by government and non-government organizations [3]

Organization	Location	Type	Installed Capacity (kW)
Grameen	Grameen offices in the coastal region	3 Hybrid	4.5
Shakti	Cyclone shelter in the coastal region	Hybrid	7.5
BRAC	Coastal region	Stand-alone	0.9
		Hybrid	4.32
Bangladesh Army	Chittagong hill tracts	Stand-alone	0.4
IFRD	Teknaf	Stand-alone	1.1
	Meghnaghat		0.6
LGED	Kuakata	Wind-PV hybrid	0.4
Total			19.72

It is estimated that currently 10% of the rural areas in Bangladesh have electricity connection and some parts of the country may not get the access of electricity from the national grid within the next 30 years [4]. Providing energy to remote areas in a sustainable way is an essential requirement nowadays. However, due to depletion of fossil fuel reserve, fuel cost escalation associated with conventional energy generation, population growth, and insufficient waste disposal facilities, off-grid hybrid energy system has become a prominent option for electricity in rural and remote areas of Bangladesh [5].

The main goal of this study is to propose a hybrid solar-diesel mini-grid system for an off-grid rural area by using the locally available energy resources. The study will examine and explain the following points. The points will also justify if the proposed hybrid mini-grid system can be a potential solution to replace the SHS in rural off-grid areas of Bangladesh.

- To perform a techno-economic feasibility study for the validation of installing a hybrid mini-grid.
- To validate the feature that hybrid mini-grid is superior to diesel-only system in terms of energy costs and environmental pollution.
- To establish the fact that hybrid mini-grid is economically feasible than SHS.
- To examine the behaviour of different uncertain components of the hybrid mini-grid on the economic prospect of the system.
- To perform a SWOT analysis, which identifies the 'strengths,' 'weaknesses,' 'opportunities,' and 'threats' of the proposed hybrid mini-grid.

1.1 Previous Studies using HOMER

Alam and Bhattacharyya [6] used HOMER to analyse a hybrid energy system for the whole coastal region of Bangladesh and proves that it is possible to propose better quality electricity for 12 to 18 hours a day for as low as USD 0.29–USD 0.31/kWh. The article suggests that depending on the location of the study area solar-diesel generator-battery or solar-wind-diesel generator-battery could be the best option. The validation of the suggestion is high because on small islands the combination of wind power and battery storage is less favourable compare to PV-battery hybrid systems due to its uneconomical condition at low wind speed [7]. Several techno-economic studies were carried out in Saint Martin's Island which is the most popular tourist destination in Bangladesh. Lipu, et al. [5] and Rashid, et al. [8] conducted an analysis of hybrid wind/PV/diesel energy system in Saint Martin's Island which demonstrates low COE (Cost of Energy) and reasonable NPC(Net Present Cost) compared to wind/battery power systems and PV/battery system. The study also reveals that proposed hybrid system emits less GHG emissions. Haque, et al. [9] showed that PV/battery system is the most optimized stand-alone system in Saint Martin's Island with COE of 0.266 USD/kWh and NPCof USD 13,79,832. However, this study has failed to prove the justification of hybrid energy system both technically and economically. The authors suggest that adding a diesel generator in the system could reduce the COE, but at the same time they show the concerns of environmental pollution due to CO₂ emission. Another study was carried out in the Saint Martin's Island where a solar/wind hybrid energy system becomes as a feasible option in terms of less COE (USD 0.227/kWh) and environmental pollution [10]. This study shows almost zero pollution due to the

nonexistence of diesel generator. Nandi and Ghosh [11] showed that a wind–PV–diesel hybrid system in Kutubdia island could be feasible with 0% capacity of shortage and by considering 5% annual capacity of shortage the wind–diesel hybrid system would reduce net present cost and cost of energy to about 20% where the diesel consumption on the island could be reduced to about 50%. The article discusses that the available wind speed at Kutubdia is high enough that combination of PV with wind turbine is not necessary to ensure better economic and technical performance. A feasibility study of a hybrid energy system conducted in Manpura Island showed that a combination of solar/wind/biogas/diesel generator/battery system gives optimum COE and NPC [12]. However, this study did not conduct the detail comparative analysis of the combination of different renewable energy sources with diesel generator. Few researches regarding hybrid off-grid energy system were done in the northern part of Bangladesh. Salehin, et al. [13] analysed a techno-economic feasibility study of a solar PV-diesel system in a remote island (Char Parbotipur) of Kurigram district which is 20 km north-east from the district and surrounded by Brahmaputra and Dudhkumar river. The study compared the feasibility of the hybrid energy system with a diesel generator only and showed that integration of Solar PV with diesel generators is more appropriate with a lower cost and environmental impact in the study area. Another study conducted by Islam, et al. [14] in northern Bangladesh revealed that cost of PV/biomass/battery/diesel hybrid mini-grid system is economical than other combinations

and the diesel-only option or the cost of owning a solar home system in Saldanga union parishad of Debiganj Upazila under the Panchagarh district. However, the study did not include wind turbine may be due to the low wind speed in the study area.

The case study locations were randomly selected by the previous researchers. However, this paper shows a methodological way to select the case study location. Moreover, none of the researchers choose the Patar Char village as a case study location. On the other hand, adding the SWOT analysis makes the study more unique and justifiable. Additionally, based on the literature review none of the previous studies in Bangladesh were done using SWOT model and HOMER. Thus, the study is novel.

2. METHODOLOGY

A theoretical block diagram of the proposed hybrid system is represented in Fig. 1. In this study, PV modules are used for base load demand, and the diesel generator is used as a standby option. If there is a shortage of electricity supply from PV module due to the instability, the standby generator will recover the shortages which enhance the reliability of the system. There are two buses in the systems which are AC and DC. The standby diesel generator is connected with the AC bus and the load demand, whereby the PV module and battery bank are connected with the DC bus, which serves the purpose of energy storage. In between the AC and DC bus, a bi-directional converter is connected.

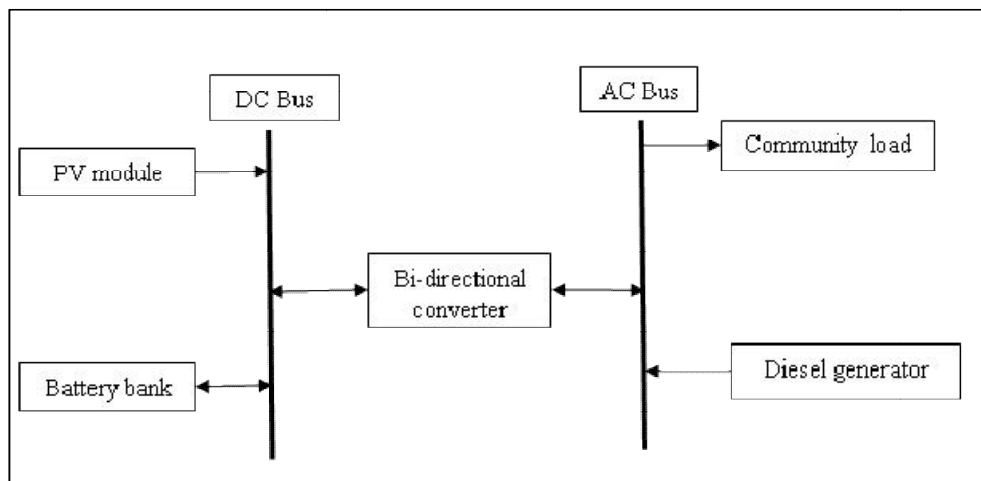

Fig. 1. Proposed block diagram of the off-grid hybrid energy system

A systematic procedure, shown in Fig. 2, is followed to get the optimal solution by HOMER software. During the process of optimization, the methodology involves: identifying a non-electrified off-grid village in the southern zone of Bangladesh, finding the available solar irradiation in the selected village, calculating the electric load requirements, and selecting the suitable technical information of system components, economic, environmental modelling of hardware components, and optimizing the system. The economic details include capital costs, replacement costs, Operation and Maintenance costs (O&M) costs, fuel price, and lifetime. The emission particulars need to evaluate the environmental analysis. HOMER does not analyse any social factor. Therefore, a qualitative strategic method SWOT is applied to understand the overall situation of the study area for the proposed hybrid energy system. Some research shows that PV/Grid system is a cost-effective system configuration and accomplishes a significant reduction in the cost of per unit electricity [15].

2.1 Study Area

2.1.1 Selection of the study area

A systematic step by step procedure is followed to select the location of the study area. Bangladesh is a country of 8 divisions, 64 districts, 491 sub-districts (upazilas) and 4554 unions [16]. Each union consists of villages. Off-grid locations are prioritized. Therefore, Barisal division is chosen as a study area, which is very near to the Bay of Bengal. The division is further divided into six districts, 41 sub-districts (upazilas), 352 unions, and 4195 villages [17]. Recently in 2018, the government of Bangladesh prioritized and finalized the list of off-grid areas. Among these, five districts are from Barisal division and according to the number of off-grid villages Patuakhali district is ahead of other districts, which have a total of 158 off-grid villages [2]. According to the last population and housing census by the government of Bangladesh, the lowest electricity connection is 0.7% in Alipur union under Dashmina Sub-district (upazila) of Patuakhali district [18]. However, Alipur is not listed as an off-grid area. Therefore, Patar Char village is decided as a final study area which is under Rangopaldi union and listed as an off-grid area. It is to be noted that presently, the study area is mostly electrified due to the rapid development of the stand-alone solar system in Bangladesh. However, still, a

significant portion of the community does not have access to electricity. Table 3 shows some off-grid regions of Patuakhali district.

2.1.2 Description of the study area

The study area Patar Char is a remote village which is surrounded by the Tetulia River. The village is located at the southern part of Bangladesh. The latitude and the longitude of the village are 22°177'N, and 90°507' E. According to the last population and housing census, the village had 200 households and 750 villagers [18]. Due to the inaccessibility of the location, primary data collection became very difficult. However, the present population of the study area is estimated by equation (1) [19]

$$N_t = P e^{r \times t} \quad (1)$$

Where,

The number of people at a future time, $N_t = N_{2018}$
 The population at the beginning time, $P = 750$
 The base of the natural logarithms, $e = 2.71828$
 The time period involved, $t = 7$
 Rate of increase, $r = 1.04$

The average rate of population increase in Bangladesh is 1.04% [20]. Therefore, the total population in the study area in 2018 is 5304. In 2018 the average household size in Bangladesh was 4.5 people per household [21]. So, the number of households in the study area is 1179. The study area is a low-lying area. The different occupational population lives in the study area. Agriculture is the most common occupation in this area. However, fishing is another skilled occupation through which people earn their livelihood. The boat is the only way of transportation for communication between the village and sub-district (upazila). Other transportation means available in the village are vans and bicycles. The climate of the study area is tropical. The average annual temperature is 25.9°C, and precipitation is 2654 mm [22]. The inhabitants of the village have to travel at least 4-5 miles to a town in order to serve their purpose.

As the village is out of national grid coverage, few households use stand-alone solar system and rest of the use of kerosene lamps and candles for lighting and fuel-wood and cow-dung for cooking purposes. Most of the villagers live under poverty, and thus, the purchasing capacity of the local people is meagre. The average income per household is around USD 70 per month. The location of the study area is displayed in Fig. 3.

Table 3. Some off-grid regions of Patuakhali district

District	Sub-district (Upazila)	Excess rate of Electricity (%)	Union	Excess rate of Electricity (%)	Off-grid village	Electricity connection (%)
Patuakhali	PatuakhaliSadar	40.4				
	Mirzaganj	33.4	N/A	N/A	N/A	N/A
	Dumki	42.5				
	Bauphal	38				
	<i>Dashmina</i>	14.1	Rangopaldi	8	Patar Char	0
	Galachipa	22.9				
	Kalapara	31.6	N/A	N/A	N/A	NA
	Rangabali	26				

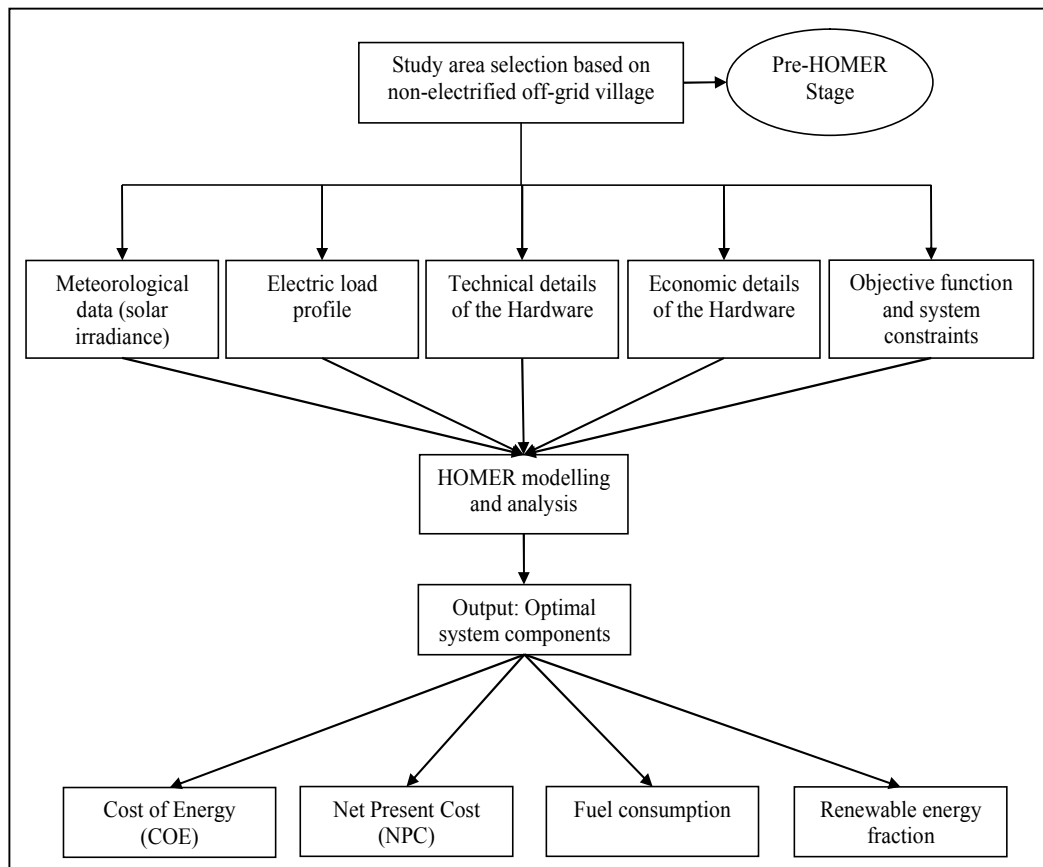

Fig. 2. Framework of the study

2.2 Primary Load Profile

It is challenging to include all the 1179 households to determine the total energy need of the community. Therefore, most of the houses use standalone solar home system (SHS). Thus, they could meet their primary need for electricity. In this research, to design the off-grid hybrid renewable energy system, only the completely non-electrified households are taken under consideration. During the survey, it was found that approximately 150 households are completely non-electrified. From Table 4, it is seen that the annual average electricity consumption of the community is estimated as 18 kWh/day. Thus, each household consumes 120 Wh/day. The peak load is calculated as 3 kW. It is to be noted that the study area is under

extreme poverty. Therefore, these 150 non-electrified houses only use energy saving bulbs and no other electrical/ electronic appliances. Fig. 4, represents the hourly load profile of the study area.

2.3 Solar Energy Resources

The monthly averaged global radiation data is taken from the power data excess viewer of NASA (National Aeronautics and Space Administration) [23]. HOMER synthesizes solar radiation values for each of the 8760 hours of the year [24]. The solar intensity of the Patar Char village varies throughout the year from 3.76 kWh/m²/d to 5.80 kWh/m²/d with a mean intensity of 4.6 kWh/m²/d and clearness index of 0.45.

Table 4. Patar char load profile

No. of the houses	No. of bulbs in each house	The power rating of each bulb (W)	Hours/day	Totalcommunity consumption (kWh/Day)
150	2	15	4	18

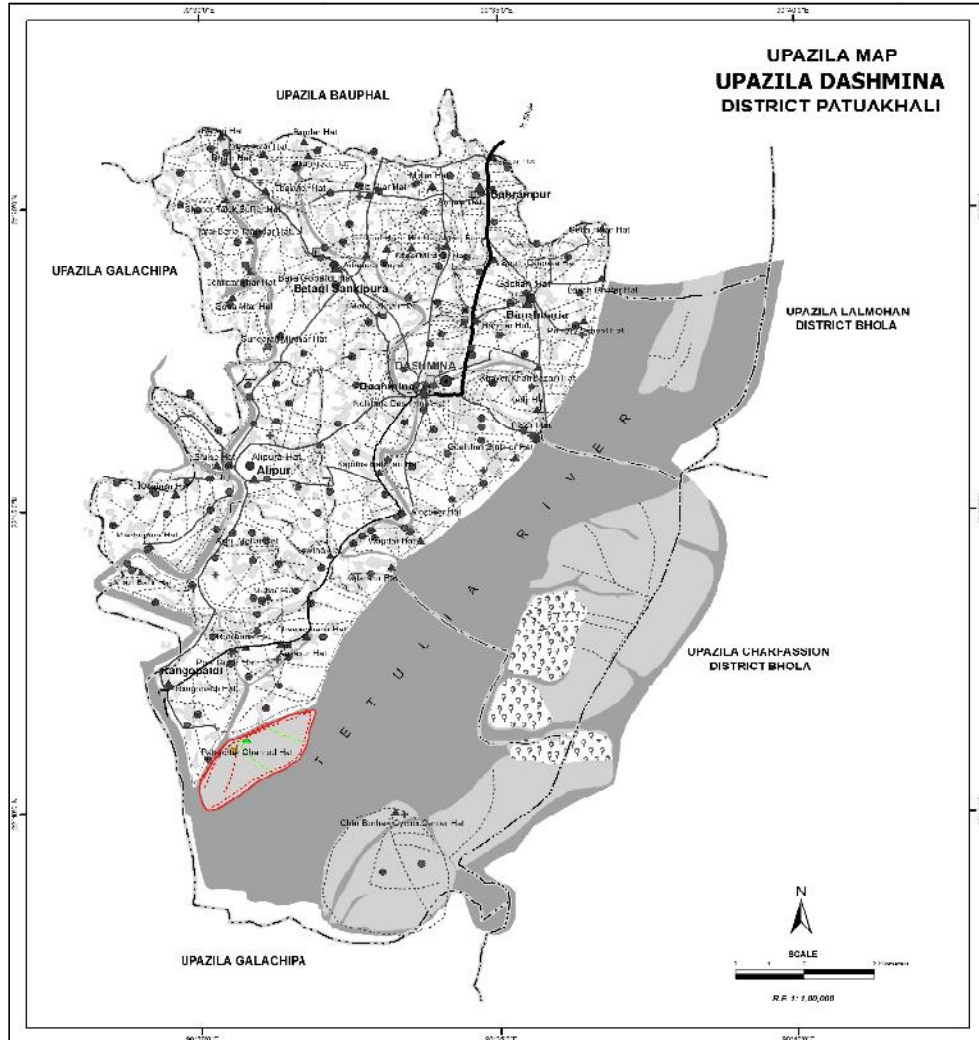

Fig. 3. Location of Patar Char in Patuakhali District

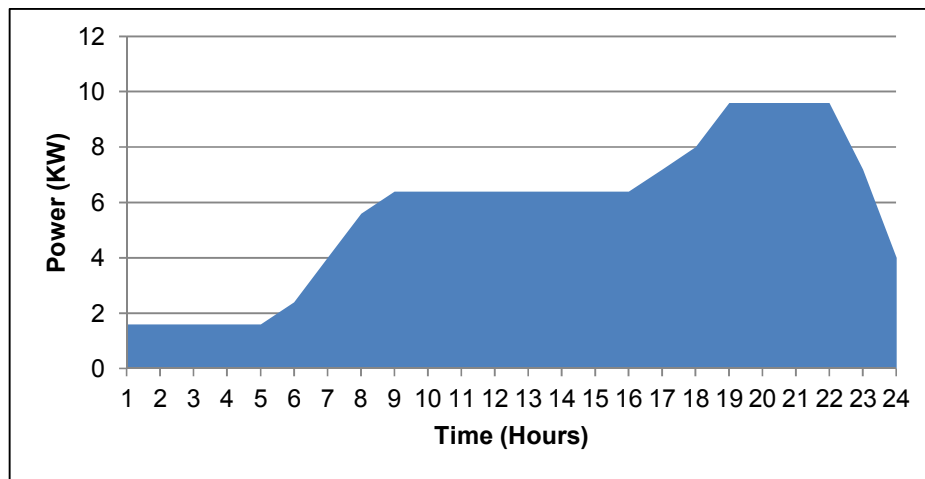

Fig. 4. Hourly load profile of Patar Char

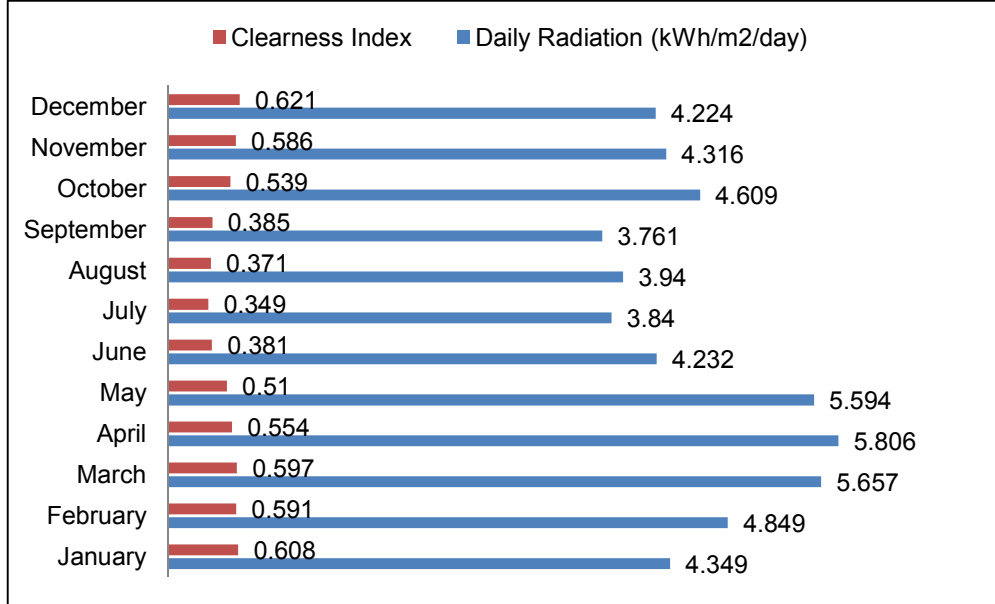

Fig. 5. Monthly solar radiation and clearness index of Patar Char

The monthly radiation and the cleanliness index of the study area are presented in Fig. 5. It is clear that the solar irradiation for the selected study area is available almost throughout the year except for the rainy season. Rainy season in Bangladesh is generally considered from July to September. The irradiation level increases between March and May, which is considered as summer season in the country.

2.4 Modelling, Sizing and Hardware Details of the System Components

2.4.1 PV modules

From the solar energy resources section, it is already found that the selected area for the case study has an abundant source of solar radiation. Therefore, the installation of the PV modules would be a competent option to solve long term energy crisis. In this research, a generic flat plate PV is considered. Solar irradiation, ambient temperature, and wind velocity are some of the factors which influence the performance of the PV output. HOMER calculates PV power output on an hourly basis by using the equation (2) [25,26]. However, in the proposed design effect of temperature on the PV array is ignored. HOMER assumes that the temperature coefficient of power is zero. Therefore, equation (2) can be rewritten as equation (3).

$$P_{PV} = Y_{PV} f_{PV} \left(\frac{\bar{G}_T}{\bar{G}_{T,STC}} \right) [1 + \alpha_P (T_c - T_{c,STC})] \quad (2)$$

$$P_{PV} = Y_{PV} f_{PV} \left(\frac{\bar{G}_T}{\bar{G}_{T,STC}} \right) \quad (3)$$

The PV capacity is considered 3 kWp (kilo Watt-peak) for the system. The capital and replacement cost for the PV module is considered as USD 350/kW, and Operation and Maintenance (O&M) cost is considered as USD 100/year [5]. The life span of the PV module is 25 years. The de-rating factor is considered 90%.

2.4.2 Battery

The function of the battery storage is to store additional energy generated by the centralized PV system and to utilize this energy when the PV fails to meet up the load demand. The function of the diesel generator is to provide backup power when PV and battery fail to fulfil the load demand. In this research, for the system design in HOMER, Generic 1 kWh Lead acid battery is chosen due to its marketable ripeness and cost-effectiveness compared to other batteries. It has the nominal voltage of 12 V, nominal capacity of 1kWh, the maximum capacity of 83.4 Ah, and the capacity ratio of 0.403. The round-trip efficiency of the battery bank is 80%. HOMER uses Kinetic Battery Model, which is a two-tank model with kinetics that matches lead-acid battery performance. Some researchers developed a mathematical model to calculate the maximum amount of power that the battery storage can be discharged (equation 4) and absorbed (equation 5) over a specific length of time [27].

$$P_{batt,dmax,kbm} = \frac{-KcQ_{max} + KQ_1 e^{-K\Delta t} + QKc(1 - e^{-K\Delta t})}{1 - e^{-K\Delta t} + c(K\Delta t - 1 + e^{-K\Delta t})} \quad (4)$$

$$P_{batt,cmax,kbm} = \frac{KQ_1 e^{-K\Delta t} + QKc(1 - e^{-K\Delta t})}{1 - e^{-K\Delta t} + c(K\Delta t - 1 + e^{-K\Delta t})} \quad (5)$$

HOMER calculates the charge or discharge power. It calculates the resulting amount of available and bound energy by using the Equations (6) and (7) [26].

$$Q_{1,end} = Q_1 e^{-K\Delta t} + \frac{(QKc - P)(1 - e^{-K\Delta t})}{K} + \frac{Pc(K\Delta t - 1 + e^{-K\Delta t})}{K} \quad (6)$$

$$\frac{Q_{2,end}}{K} = Q_2 e^{-K\Delta t} + Q(1 - C)(1 - e^{-K\Delta t}) + \frac{P(1 - c)(K\Delta t - 1 + e^{-K\Delta t})}{K} \quad (7)$$

The nominal voltage of this battery is 12V, maximum capacity is 83.4 Ah, and the capacity ratio is 0.403. The nominal capacity of the battery is 1 kWh with an average lifetime of 10 years. The capital and replacement of the battery are considered USD 75/Piece [28]. Operation and Maintenance (O&M) cost is considered 5% of the battery cost.

2.4.3 Inverter

A bi-directional inverter is considered in the system. It connects with a DC and an AC bus. Therefore, from PV modules and battery, it converts the DC voltage to AC voltage and supplies energy to the load. Similarly, from the diesel generator with the excess energy, it converts AC voltage to DC voltage to charge the battery. The efficiency of the load side of an inverter is expressed by equation (8) [29].

$$\eta_{inv} = \frac{P_{out}}{P_{in}} \quad (8)$$

Generally, converter size is considered 25-30% bigger than the total Watts of appliances. Here, for the proposed system, a 3 kW converter is used. The capital and replacement cost of the converter is considered as USD 150/kW with an average lifetime of 15 years [30]. Here, O&M cost is considered as zero.

2.4.4 Back-up generator

A generator is a device that produces electrical energy by consuming fuel. A backup generator is an electrical system that operates when there is insufficient energy to supply to the load. Generally, a diesel generator is an extensively suitable source to generate electricity in the

remote areas to provide consistent community load: cheaper costs and capability to generate electricity as per necessities of the demand site in contrast to the renewable energy sources. Solar panels produce the most electricity on clear days with abundant sunshine, but on cloudy days, solar panels can only produce 10-25% electricity of their rated capacity. In the research, an Auto sized generator is considered, which can provide enough power to fulfil the load demand during adverse weather conditions. The efficiency of a diesel generator is considered as 35%. The maximum load ratio of the generator is 25%. The fuel consumption for electricity production is calculated using equation (9) [31].

$$F = F_{0,dg} Y_{dg} + F_{1,dg} P_{dg} \quad (9)$$

Where, F_0 is the fuel curve intercept coefficient (0.000205 m³/h), F_1 is the fuel curve slope (0.00025 m³/h/kW), Y_{dg} (kW) is the rated capacity of the generator and P_{dg} (kW) is the electrical output of the generator. The lower heating rate of diesel is 43.2 MJ/kg with a concentration of 820 kg/ m³ [31].

The capital and replacement cost of the generator is considered as USD 700/kW with Operation and Maintenance (O&M) cost at USD 0.05/hour [32]. The fuel price is USD 0.77/litre [33].

2.5 Economic Model for the System

The Total Net Present Cost (TNPC) is utilized to illustrate the life cycle cost of the system in HOMER. The TNPC includes initial capital costs, replacement costs, O&M costs, salvage values, fuel costs, and cost of power, which is purchased from the grid. It also includes other penalty costs for greenhouse gas emissions. Equation (10) is used to estimate TNPC in HOMER, whereby, C_{TA} is the total annualized cost (USD/year) and CRF is the capital recovery factor [34].

$$TNPC = \frac{C_{TA}}{CRF} \quad (10)$$

The following equation determines CRF, whereby, whereby 'i' is the annual interest rate (%) and N is the total project lifetime (years) [34].

$$CRF = \frac{i(1+i)^n}{i(1+i)^n - 1} \quad (11)$$

Here, the annual real interest rate (i) can be computed by equation (12) whereby, i' is the nominal interest rate, and f is the annual inflation

rate. A discount rate of 8% and an annual inflation rate of 2% are used in this study.

$$i = \frac{i'-f}{1+f} \quad (12)$$

The Cost of Energy (COE) is the proportion of the annualized cost of system components to the total energy generation. The Equations (13) and (14) is used to estimate the COE whereby E_T is the total energy served, C_A is the total annual cost which includes annual capital (C_{A_Cap}), annual replacement (C_{A_Rep}), annual operation and maintenance cost ($C_{A_O\&M}$) [35].

$$COE = \frac{C_A}{E_T} \quad (13)$$

$$C_A = C_{A_Cap} + C_{A_Rep} + C_{A_O\&M} \quad (14)$$

3. RESULTS AND DISCUSSION

In this study, three cases are investigated for the designed hybrid mini-grid system. During the design stage, the accessibility of the local power generation resources is carefully considered. After the verification of the design, HOMER chooses the optimized system for each case that fulfils the requirement of the load demand. The simulation results for the Hybrid mini-grid system are shown in Table 5.

The simulation results show that Case A is optimal than Case B and Case C in terms of the lower cost of energy (USD/kWh) and total net present cost (USD). Regarding the system sizing, Case A consists of 6.72 kW Photovoltaic Panel, 2.5 kW Diesel generator, 48 kWh Lead Acid Battery and 2.40kW system converter with the load following dispatch strategy.

3.2 Electricity Production

The annual electricity production of Case A is 11,223 kWh/year, whereby 97.48% (10,945

kWh/year) comes from the photovoltaic panel and 2.48% (278 kWh/year). The hours of operation of the photovoltaic panel are 4,370 hours/year, and a diesel generator is 370 hours/year. Fig. 6, shows the average fuel consumption intensity of diesel generator throughout the year. Fig. 7, displays the average monthly electricity production of Case A.

The share of renewable energy is 95.8%. The system configuration of Case A does not have any unmet load and capacity shortage. However, it has 30% (3,366 kWh/year) excess electricity production than the demand. In this situation, batteries do not have the extra capacity to store excess electricity. This excess electricity cannot be reduced further with lesser production capacity. It is because the system reliability can be affected severely. Increasing the battery capacity could be one tactic to trim down the excess electricity.

On the other hand, it could be an expensive option due to higher battery storage costs and conversion costs. Among the three cases, Case A generates the lowest excess electricity while Case B produces the highest excess electricity. It is evident that due to higher solar irradiation, Case B causes a significant amount of excess electricity.

3.2 Economic Analysis

Fig. 8 shows the cost summary of Case A. The total net present cost, operating cost, and initial capital cost is USD 15,627, USD 585.28 and USD 8,061.27 respectively. The cost of energy is USD 0.183/kWh. According to the Bangladesh Energy Regulatory Commission (BERC), retail electricity tariff for residential consumer up to 200 kWh is USD 0.07/kWh [36]. Similar research shows a PV/Biomass/Battery/Diesel hybrid mini-grid system incurs the cost of energy at USD 0.188/kWh [14].

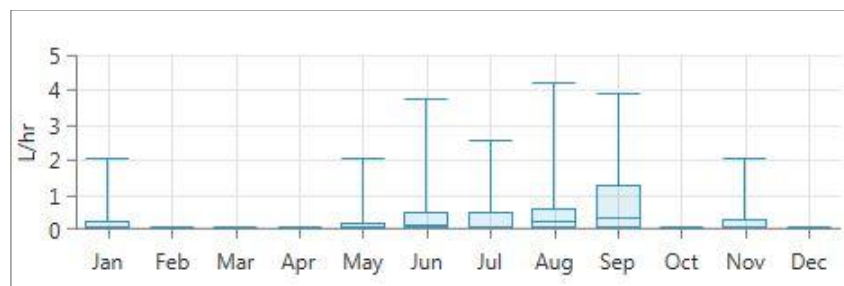

Fig. 6. Average fuel consumption intensity of diesel generator

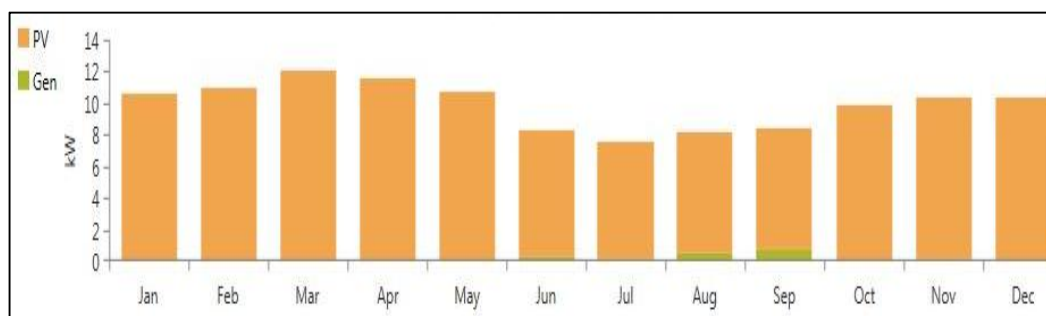

Fig. 7. Average monthly electricity production of Case A

After the comparison of the costing, it is noticeable that the estimated cost of energy is 2.5 times higher than the residential consumer tariff of Bangladesh. Therefore, it is far away from grid parity. The reason behind is the subsidies applied by the government to generate electricity from conventional power plants. On the other hand, a solar home system (SHS) costs around USD 0.72/kWh in the off-grid areas of Bangladesh, and the cost is twice compared to the diesel-based mini-grid system which is USD 0.36/kWh [37]. Therefore, the proposed hybrid system Case A has a higher economic benefit (COE=USD 0.18/kWh) than the SHSs (COE=USD 0.72/kWh). Also, the system has a lower cost of energy compared to Case B (USD 0.24/kWh) and Case C (USD 0.44/kWh).

Additionally, the investment and life-cycle cost of SHS is not economically feasible when it is compared with the hybrid energy system. In contrast to the hybrid energy system, SHS is unable to provide reliable and regular electricity service. During the selection of the most optimized Case A, three parameters were considered, which are reliability, quality, and Cost of Energy. In the future, it will be challenging to connect the study area with the national grid. Therefore, a Solar-Diesel hybrid system will be more competent than a stand-alone PV module system or a diesel-only system. It is technically possible to electrify 290 households in the off-grid village by using SHS system or the biogas. However, in terms of the reliability, cost, and continuous energy supply, a Solar-Diesel hybrid energy system is best fitted.

3.3 Environmental Analysis

In this study, Case A is investigated on the grounds of environmental benefits. The leading cause of environmental pollution in the study area is kerosene. Therefore, the environmental

benefit is analysed based on the current kerosene fuel consumption of the Patar Char village. The kerosene consumption is compared with the grid connected and diesel generator-based power generation system. The survey revealed that the present kerosene consumption in the study area is about 0.0432 litres/hour. It was assumed that each household uses kerosene for 4 hours/day. Therefore, 290 households use 18,291 litres of kerosene per year. It is estimated that carbon dioxide (CO₂) emission from kerosene is 2.5 kg/litres [38]. So, the total emission of CO₂ from kerosene is estimated at 45,727 kg per year. An electricity grid emission factor of Bangladesh is 0.637 kg-CO₂/kWh [39]. Therefore, CO₂ emission for Grid supplied energy is calculated based on the electricity need of 11,223 kWh/year for Case A. After estimation it is found that the rate of emission from the grid electricity is 7,149 kg/year. It is significant that the proposed hybrid system emits only 307 kg-CO₂/year, whereby, the diesel-only system of Case C emits 6,060 kg-CO₂/year. From Table 6, it is seen that the proposed PV/Batt/Diesel (Case A) hybrid system reduces around 95% CO₂ than the diesel-only system, 96% CO₂ compared to grid electricity. It is surprising and exciting that the proposed hybrid mini-grid would generate about 99% lower CO₂ emission than the existing method (Kerosene).

3.4 Sensitivity Analysis

Sensitivity analysis is performed to study the behaviour under the uncertainty of different factors of a system. In this study, the effect of variation of different input parameters on COE and TNPC of Case A is investigated. Here, the impact of price variability in diesel price, discount rate on the cost of per unit energy, and total net present cost were analysed. At first, the price of the diesel fuel changed to 0.66 USD/L to 1.21

Table 5. Simulation results for the Hybrid mini-grid system

No.	Narrative		Case A PV/ Battery/Diesel Generator	Case B PV/ Battery	Case C Diesel Generator/ Battery
1.	System Sizing	PV (kW)	6.72	13.7	-
		Diesel Generator (kW)	2.5	-	2.5
		Battery (kWh)	48	65	21
		Converter (kW)	2.40	5.78	1.24
2.	Electricity Production (KWh/Year)	Total Electricity	11,223	22,330	7,796
		PV	10,945	22,330	-
		Diesel Generator	278	-	7,796
		AC Primary Load	6,665	6,660	6,645
		Unmet Load	0	5.40	0
		Capacity Shortage	0	6.61	0
		Excess Electricity	3,366	14,483	0
3.	Economics	Net Present Cost (USD)	15,627.53	20,720.27	38,521.75
		Cost of Energy (USD/kWh)	0.182	0.242	0.448
		Capital Cost (USD)	8061.27	10,539.48	3,510.78
		Operating Cost (USD)	585.28	791.40	2,708.24
		Fuel Cost (USD)	1,167.56	-	23,045.64
4.	Emissions (kg/year)	CO ₂	307	-	6,060
		CO	1.94	-	38.2
		Unburned Hydrocarbons	0	-	1.67
		SO ₂	0.75	-	14.8
		NO ₂	1.82	-	35.9
		TSP (Dust)	0	-	0.232
5.	Total Fuel Consumption	Diesel(litres)	117	-	2,315
6.	Battery Performance	Energy In (kWh/year)	4,312	4,232	3,870
		Energy Out (kWh/year)	3,460	3,395	3,097
7.	Renewable Fraction (%)		95.8	100	0

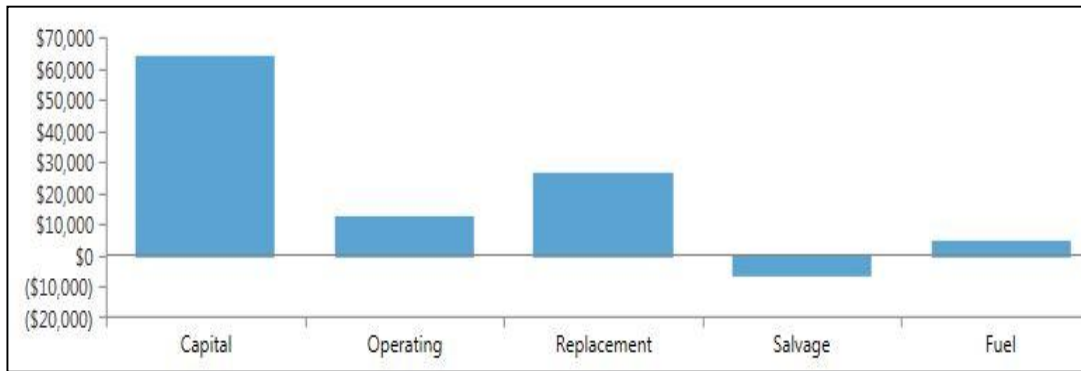

Fig. 8. Cost detail of Case A

Table 6. CO₂ emission comparison of different technologies

Scenarios	CO ₂ emissions (kg/year)
Case A (Optimal)	307
Kerosene	45,727
Power Grid	7,149
Diesel only	6,060

USD/L, and its result on COE and TNPC checked accordingly. From Fig. 9, it is found that both COE and TNPC increase drastically with the increasing price of diesel. Later, the discount rate varied from 2-10% and applied to the COE and TNPC.

From Fig. 10, it is seen that the lower discount rate reduced COE and higher NPC for the system. A sensitivity analysis with respect to

solar irradiation, CO₂ emission, diesel price, and cost of energy also analysed. For this analysis solar irradiation varied from 4-6.5 kWh/m²/day.

From Fig. 11, it is found that with the increase of solar irradiation and decreasing of diesel fuel price, the cost of energy is reduced.

However, from Fig, 12, it is found that the emission of CO₂ trimmed down with an increase in solar radiation and diesel fuel price.

3.5 SWOT Analysis

The SWOT Analysis is an investigation process which is used to assess the 'strengths,' 'weaknesses,' 'opportunities' and 'threats' involved in an organization, a plan, a project, a person or a business activity [40]. This analysis

Table 7. SWOT analysis

Strengths	Weaknesses
<ul style="list-style-type: none"> An appropriate geographic location which has an ample amount of solar irradiation Low environmental impact. The proposed hybrid system can minimize carbon footprint The system can save electricity costs The proposed hybrid energy system has good reliability Fuel transportation is not required Low operation and maintenance costs. Almost no noise. 	<ul style="list-style-type: none"> Weak technical infrastructure High installation costs of PV and diesel generator Delay of decision-making from the policy level Bidding procedure and documentation Lack of coordination between the client (government bodies) and consultants/contractors Project implementation delay increases cost Lack of Clean Energy Research Centres.
Opportunities	Threats
<ul style="list-style-type: none"> Creation of new jobs Expand into new areas of business in the energy sector Awareness programs will guide the people to know more about off-grid hybrid energy 	<ul style="list-style-type: none"> Political uncertainty Lack of investors and technical personals Wrong energy policy.

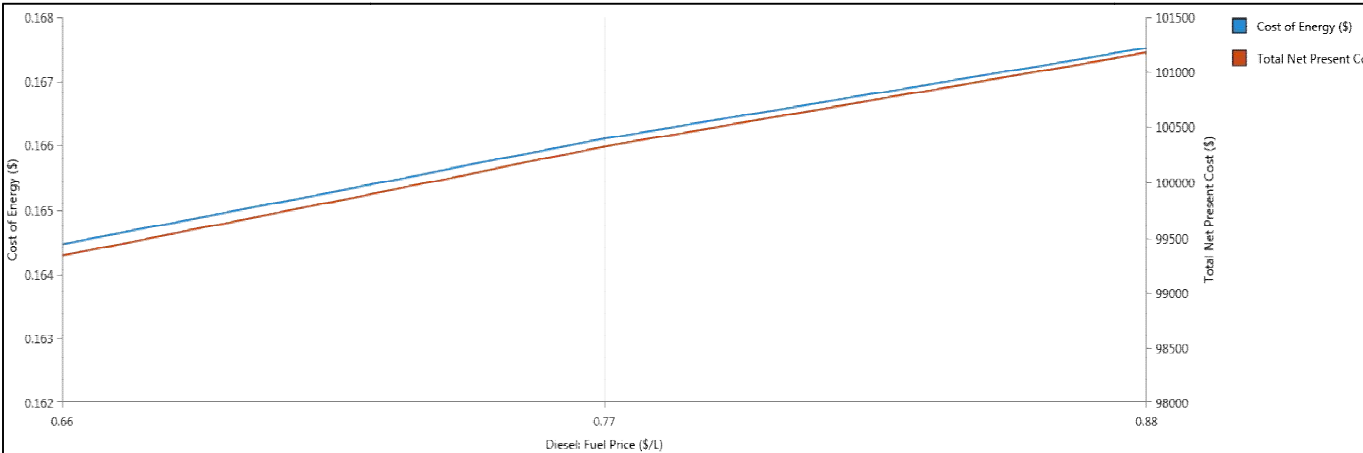

Fig. 9. COE and TNPC with the price of diesel

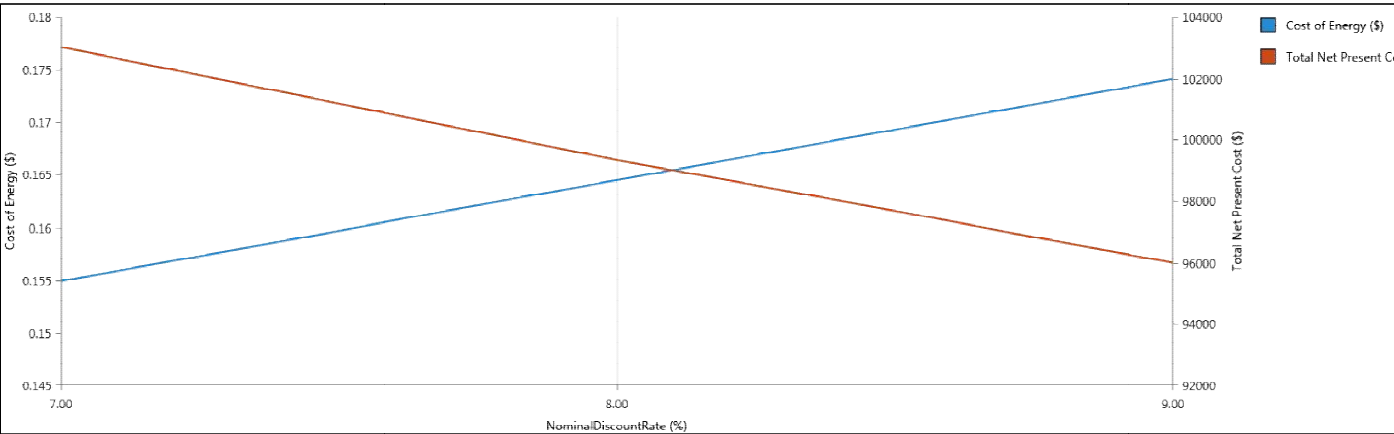

Fig. 10. COE and TNPC with the discount rate

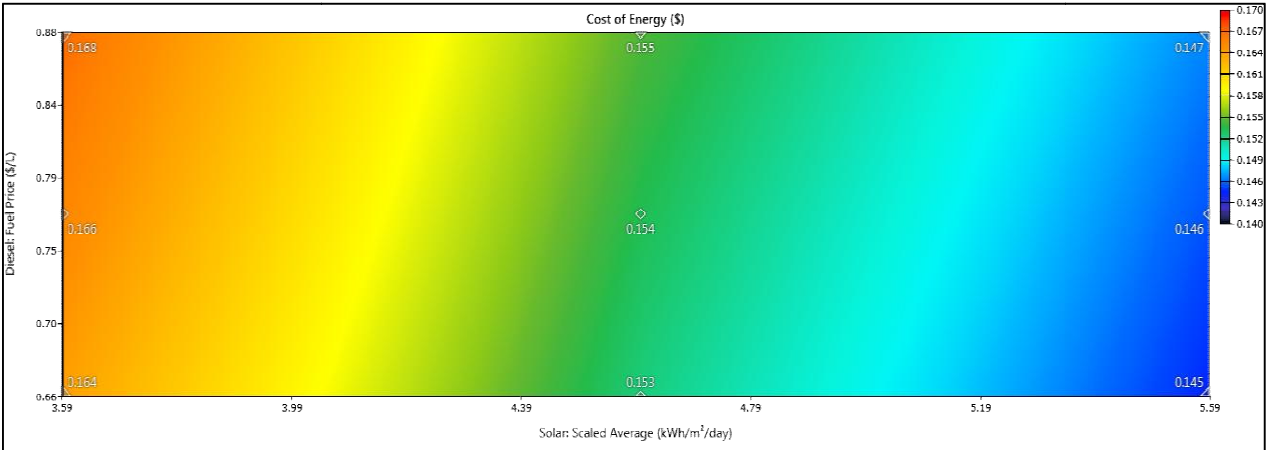

Fig. 11. COE with solar radiation and the price of diesel

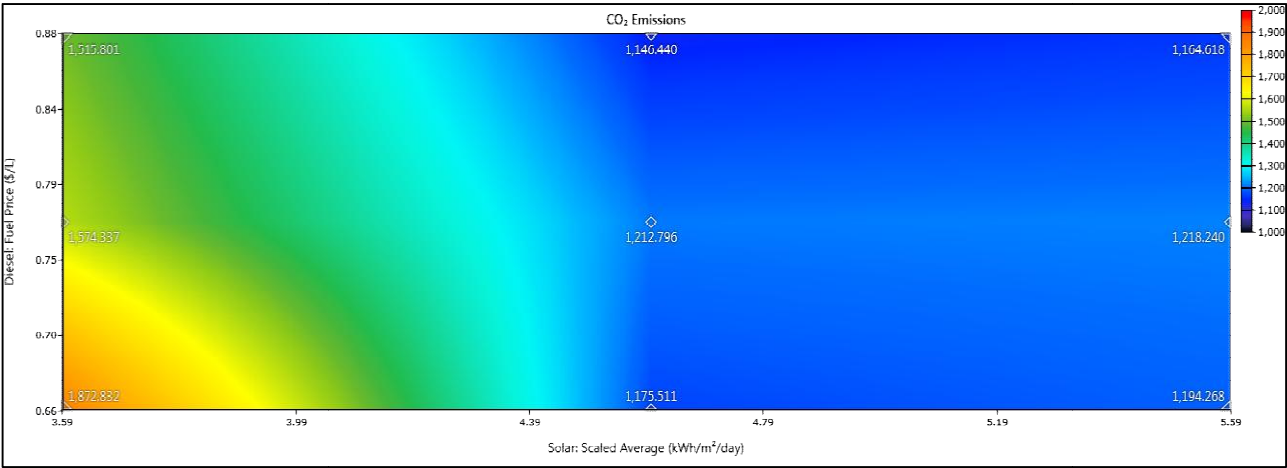

Fig. 12. CO₂ emissions with solar radiation and the price of diesel

is divided into the internal and external environment. The internal environment contains 'strengths' and 'weaknesses,' whereby the external environment contains 'opportunities' and 'threats.' SWOT analysis is a pioneer to strategic planning. It is performed by a panel of experts who can assess the organization from a critical perspective [41]. This panel of experts can be senior leaders, employees, community leaders, technical experts, etc.

Furthermore, it is also effectively used as a method for participatory planning [42]. Participatory planning aims to include more participation in decision-making, increase the permissibility of politicians and officials, and give more criticism of experts' plans [43]. Therefore, to perform a SWOT analysis, participatory planning strategy is applied to the locals in Patar Char Village to understand the technical, economic, social, and environmental aspects of the proposed hybrid energy system. The result of SWOT analysis is described in Table 7.

4. CONCLUSION

After the analysis, the following conclusions are drawn.

- In this paper, we have presented a techno-economic analysis of renewable energy source-based hybrid mini-grid, with a case study area of Bangladesh, in HOMER simulation environment. The fuels which are currently being used in large part of the rural areas are dangerous for the health of the inhabitants. Toxic gas emission from kerosene makes the environment worse. Current initiatives using solar home system (SHS) is expected to be replicated with a mini-grid with the view to have a more reliable and cost-effective power generation. After a survey in the case study area, a techno-economic model is presented, and the simulation shows that the hybrid mini-grid can decrease more than 90% carbon-footprint compared to the existing system (kerosene).
- Although SHS is being used immensely in Bangladesh, it often shows the lack of ability to supply consumers' energy demand adequately and consistently. Due to the resource constraint, it is not fit for small to large-scale industries. It is also notable that the cost of electricity supply through hybrid mini-grid is economically feasible than the cost of owning an SHS for the rural people [37]. Therefore, the

proposed hybrid energy system can overcome the aberrant behaviour of renewable energy resources and can improve system performance.

- Next step is to use the results to analyse the hybrid grid as a community program. Through proper and active involvement of several companies and NGOs interested in renewable energy, the results will help to make the inhabitants aware of their energy crisis, safety and health hazards, environmental issues, etc. The hybrid mini-grid will undoubtedly improve the quality of life of the inhabitants in terms of responsible standards of energy consumption, health, and environmental impact. However, a more in-depth analysis is required to make the energy supply more sustainable, economically viable, and environmentally safe for the community.
- The high fuel crisis is one of the reasons that the Bangladesh power sector is susceptible. Also, it requires enormous investment to connect off-grid areas with the national grid. Therefore, it is not only economically affordable but also not sustainable. In this regard, the combination of solar photovoltaic and diesel generator can play a vital role. The study shows that hybrid solar-diesel mini-grid in remote areas is a suitable option in terms of lowest generation costs compared to the diesel supply or standalone SHS. However, government incentives policy is highly essential to achieve grid parity. Without government support, the hybrid mini-grid system could not reach grid parity, which may adversely affect the proposed plant. The energy price from power grid of Bangladesh is highly subsidized. Therefore, it affects the competitiveness and security of renewable energy technologies. In this circumstance, a comprehensive energy policy towards rural electrification through renewable energy based hybrid mini-grid is vital.

COMPETING INTERESTS

Authors have declared that no competing interests exist.

REFERENCES

1. IDCOL. Renewable Energy. Available:<http://idcol.org/home/penergy> [Accessed 18-May-2019]

2. SREDA, Sustainable & Renewable Energy Development Authority.
Available:<http://www.sreda.gov.bd/>
[Accessed: 18-May-2019]
3. Islam M. Renewable Energy Prospects & Trends in Bangladesh; 2013.
4. Das HS, Yatim AHM, Tan CW, Lau KY. Proposition of a PV/tidal powered micro-hydro and diesel hybrid system: A southern Bangladesh focus. *Renew. Sustain. Energy Rev.* 2016;53:1137–1148. DOI: 10.1016/j.rser.2015.09.038
5. Hossain MS, Lipu MG, Hafiz MS, Ullah A Hossain, Munia FY. Design optimization and sensitivity analysis of hybrid renewable energy systems: A case of Saint Martin Island in Bangladesh. *Int. J. Renew. Energy Res.* 2017;7(2):988–998. DOI: 10.9790/487X-1901035964
6. Alam MSB. Energies and undefined. Decentralized renewable hybrid mini-grids for sustainable electrification of the off-grid coastal areas of Bangladesh; 2016.
Available: mdpi.com
7. Blechinger P, Seguin R, Cader C, Bertheau P, Breyer C. Assessment of the global potential for renewable energy storage systems on small islands. *Energy Procedia*; 2014.
8. Rashid S, Rana S, Shezan S. Optimized design of a hybrid PV-wind-diesel energy system for sustainable development at coastal areas in Bangladesh. *Environ. Prog. Sustain. Energy*; 2017.
9. Haque KF, Saqib N, Rahman MS. An optimized stand-alone green hybrid grid system for an offshore Island, Saint Martin, Bangladesh. *International Conference on Energy and Power Engineering (ICEPE)*. 2019;1–5.
10. Fardun MBM, Sunny KSI, Satter MDA. Modelling and optimization of hybrid power system at Coastal Area. *International Conference on Electrical, Computer and Communication Engineering (ECCE)*. 2019;1–6.
11. Nandi SK, Ghosh HR. Techno-economical analysis of off-grid hybrid systems at Kutubdia Island, Bangladesh. *Energy Policy*. 2010;38(2):976–980.
12. Arefin M, Raihan M, Alvee H, Istiaque M. A study on feasibility of renewable hybrid power generation plant in Manpura Island. In *Proceedings of the International Conference on Mechanical Engineering and Renewable Energy*; 2017.
13. Salehin S, Rahman M, Islam AKMS. Techno-economic feasibility study of a solar PV- diesel system for applications in Northern Part of Bangladesh. *Int. J. Renew. Energy Res.* 2015;5(4):1220–1229.
14. Islam MS, Akhter R, Rahman MA. A thorough investigation on hybrid application of biomass gasifier and PV resources to meet energy needs for a northern rural off-grid region of Bangladesh: A potential solution to replicate in rural off-grid areas or not? *Energy*. 2018;145:338–355.
DOI: 10.1016/j.energy.2017.12.125
15. Islam MS. A techno-economic feasibility analysis of hybrid renewable energy supply options for a grid-connected large office building in southeastern part of France. *Sustain. Cities Soc.* 2018;38:492–508.
DOI: 10.1016/j.scs.2018.01.022
16. Bangladesh Bureau of Statistics (BBS). *Bangladesh Statistics 2018*, Dhaka; 2018.
17. Bangladesh Government. Barishal Division; 2019.
Available:<http://www.barisaldiv.gov.bd/site/page/>
[Accessed 18-May-2019]
18. Bangladesh Bureau of Statistics (BBS). *Population and Housing Census 2011*, 4th ed. Statistics and Informatics Division (SID), Ministry of Planning; 2012.
19. Eurostat. *Population projections*. *Comput. Human Behav.* 2011;24(2):346–360.
DOI: 10.1016/j.chb.2001.01.019
20. United Nations. *World Population Prospects*; 2017.
Available:<https://population.un.org/wpp/Download/Standard/Population/>
[Accessed: 18-May-2019]
21. ArcGIS. *Bangladesh Average Household Size*; 2018.
Available:<https://www.arcgis.com/home/item.html?id=692cee7e5a5e47dd86531ab0c6a00cff>
[Accessed: 18-May-2019]
22. Climate-Data. *Climate Patuakhali*; 2019.
Available:<https://en.climate-data.org/asia/bangladesh/barisal-division/patuakhali-59245/>
[Accessed: 18-May-2019]

23. NASA. POWER Data Access Viewer; 2019.
Available: <https://power.larc.nasa.gov/data-access-viewer/>
[Accessed: 18-May-2019]
24. Mahmud N, Hassan A, Rahman MS. Modelling and cost analysis of hybrid energy system for St. Martin Island using HOMER. 2013 Int. Conf. Informatics, Electron. Vision, ICIEV 2013; 2013.
DOI: 10.1109/ICIEV.2013.6572678
25. Olatomiwa L. Optimal configuration assessments of hybrid renewable power supply for rural healthcare facilities. *Energy Reports*. 2016;2:141–146.
DOI: 10.1016/j.egy.2016.06.001
26. Ronad BF, Jangamshetti SH. Optimal cost analysis of wind-solar hybrid system powered AC and DC irrigation pumps using HOMER. 2015 Int. Conf. Renew. Energy Res. Appl. ICRERA 2015. 2015;5: 1038–1042.
DOI: 10.1109/ICRERA.2015.7418568
27. Manwell JF, McGowan JG. Lead acid battery storage model for hybrid energy systems. 1993;50(5):399–405.
28. Hefei Bluesun Solar Energy Tech. Co. Ltd., “Bluesun Solar Storage Battery; 2019.
Available:<https://www.alibaba.com/>
[Accessed: 18-May-2019]
29. Brka A, Al-Abdeli YM, Kothapalli G. Predictive power management strategies for stand-alone hydrogen systems: Operational impact. *Int. J. Hydrogen Energy*. 2016;41(16):6685–6698.
DOI: 10.1016/j.ijhydene.2016.03.085
30. Khan NA, Sikder AK, Saha SS. Optimal planning of off-grid solar-wind-tidal hybrid energy system for sandwip island of Bangladesh. 2014 2nd Int. Conf. Green Energy Technol. ICGET 2014. 2014;41–44.
DOI: 10.1109/ICGET.2014.6966658
31. Khalid F, Dincer I, Rosen MA. Thermo-economic analysis of a solar-biomass integrated multigeneration system for a community. *Appl. Therm. Eng.* 2017; 120:645–653.
DOI:10.1016/j.applthermaleng.2017.03.040
32. Das BK, Hoque N, Mandal S, Pal TK, Raihan MA. A techno-economic feasibility of a stand-alone hybrid power generation for remote area application in Bangladesh. *Energy*. 2017;134:775–788.
DOI: 10.1016/j.energy.2017.06.024
33. Global Petrol Prices. Bangladesh Diesel prices, liter; 2019.
Available:https://www.globalpetrolprices.com/Bangladesh/diesel_prices/
[Accessed: 18-May-2019]
34. Li C, Ge X, Zheng Y, Xu C, Ren Y, Song C, Yang C. Techno-economic feasibility study of autonomous hybrid wind/PV/battery power system for a household in Urumqi, China. *Energy*. 2013;55:263–272.
DOI: 10.1016/j.energy.2013.03.084
35. Hiendro A, Kurnianto R, Rajagukguk M, Simanjuntak YM, Junaidi. Techno-economic analysis of photovoltaic/wind hybrid system for onshore/remote area in Indonesia. *Energy*. 2013;59:652–657.
DOI: 10.1016/j.energy.2013.06.005
36. Bangladesh Energy Regulatory Commission. BERC Retail Electricity Tariff; 2017.
Available:<http://www.berc.org.bd/site/notice/s/61619908-d607-4a5a-b301-6f029f6f0472/BERC-Retail-Electricity-Tariff->
[Accessed: 18-May-2019]
37. Bhattacharyya SC. Mini-grid based electrification in Bangladesh: Technical configuration and business analysis. *Renew. Energy*. 2015;75:745–761.
DOI: 10.1016/j.renene.2014.10.034
38. Hoque SMN, Das BK. Analysis of cost, energy and emission of solar home systems in Bangladesh. *Int. J. Renew. Energy Res.* 2013;3(2):347–352.
39. Brander AM, Sood A, Wylie C, Houghton A, Lovell J, Reviewers I, Davis G. Electricity-specific emission factors for grid electricity. *Ecometrica*. 2011;1–22.
DOI: 10.13044/j.sdewes.2014.02.0030
40. Gürel E, Tat M. Swot analysis: A theoretical review. *J. Int. Soc. Res.* 2017;10(51).
DOI:<http://dx.doi.org/10.17719/jjsr.2017.1832>
41. Gibis B, Artiles J, Corabian P, Meiesaar K, Koppel A, Jacobs P, Serrano P, Menon D. Application of strengths, weaknesses, opportunities and threats analysis in the

- development of a health technology assessment program. Health Policy (New York). 2001;58(1):27–35.
DOI: 10.1016/S0168-8510(01)00149-X
42. Rauch P, et al. SWOT analysis and strategy development for forest fuel supply chains in South East Europe. For. Policy Econ. 2015;61(2015):87–94.
DOI: 10.1016/j.forpol.2015.09.003
43. Murray M. Participatory Rural Planning : Exploring Evidence from Ireland. Taylor & Francis Ltd; 2010.

© 2020 Ali et al.; This is an Open Access article distributed under the terms of the Creative Commons Attribution License (<http://creativecommons.org/licenses/by/4.0>), which permits unrestricted use, distribution, and reproduction in any medium, provided the original work is properly cited.

Peer-review history:
The peer review history for this paper can be accessed here:
<http://www.sdiarticle4.com/review-history/53973>