



Overvoltages during Single-Phase Earth Fault in Neutral-Isolated Networks (10÷35) kV

S. V. Rzayeva^a, N. S. Mammadov^{a*} and N. A. Ganiyeva^a

^a Department of the Electromechanics, Azerbaijan State Oil and Industry University, Azadliq prospekti 34, Baku, Az10101, Azerbaijan.

Authors' contributions

This work was carried out in collaboration among all authors. All authors read and approved the final manuscript.

Article Information

DOI: 10.9734/JENRR/2023/v13i1253

Open Peer Review History:

This journal follows the Advanced Open Peer Review policy. Identity of the Reviewers, Editor(s) and additional Reviewers, peer review comments, different versions of the manuscript, comments of the editors, etc are available here: <https://www.sdiarticle5.com/review-history/94649>

Original Research Article

Received: 18/10/2022

Accepted: 20/12/2022

Published: 05/01/2023

ABSTRACT

Aims: The purpose of the article is to analyze networks with zero insulation (10 ÷ 35) kV, which have disadvantages that adversely affect the insulation of operating equipment, as a result of which, in modern conditions, it is desirable to improve the operating modes of such networks.

Place and Duration of Study: Department of Electromechanics (Electrical and electronic engineering).

Methodology: To limit the surges that occur in such networks, an arc quenching coil is used, the operation of which is based on two processes: a coil that compensates for the capacitive current, a sharp decrease in the voltage recovery rate in the arc range.

Results: In connection with the above, by carrying out accurate calculations, it is necessary to solve a number of issues on grounding the neutral with active resistance in networks (10÷35) kV: effective grounding of networks, ensuring safety, limiting the impact on communication lines, limitation of emerging surges, ensuring normal operation of switching devices, etc.

Conclusion: 1. Due to the difficulty of obtaining an accurate adjustment when earthing the neutral through an arcing coil, and even under normal conditions, overvoltages in the phases are likely as a

*Corresponding author: E-mail: nijatms@gmail.com, nicat.memmedov.sa@asoiu.edu.az;

result of the displacement of the neutral. 2. Networks with zero insulation (10÷35) kV have disadvantages that adversely affect the insulation of operating equipment, and in modern conditions it is desirable to improve the operating modes of such networks. 3. In networks with an isolated neutral (10÷35) kV, the connection of the neutral to earth with active resistance allows you to significantly limit the extreme voltages that may occur in the network.

Keywords: Voltage; neutral; coil; single-phase ground fault; electrical concrete; resistance.

1. INTRODUCTION

The vast majority of accidents occurring in networks (10÷35) kV occur due to single-phase earth faults and resulting overvoltages. With a constant short circuit of one phase to earth in networks with an isolated neutral, the voltage in healthy phases increases from linear to $U_x = \sqrt{3}U_f$. U_x – linear voltage, U_f – phases voltage. Such a voltage does not pose a threat to the network, the insulation of which is not damaged at this moment. In addition, the vast majority of single-phase earth faults in networks with zero insulation are due to the formation of an unstable arc. The arc repeatedly flashes until it is completely extinguished - the flash of the arc causes repeated electromagnetic switching processes, which leads to the occurrence of over voltages [1]. The reason for the formation of extreme voltages during repeated flashes of the arc is that when the arc is extinguished, an electric charge remains in the phase capacitances, as a result of which the neutral of the network is displaced. Thus, single-phase earth faults and the magnitude and nature of over voltages occurring during this time determine the conditions for burning and extinguishing the arc.

The purpose of the presented work is to analyze the extreme voltages that occur during single-phase earth faults and to determine how to limit them.

Formulation of the problem: To limit the surges that occur in such networks, an arc quenching coil is used, the operation of which is based on two processes: 1) the coil compensates for the capacitive current. 2) a sharp decrease in the voltage recovery rate in the arc range [2,3]. With full regulation of the winding, only the active current will flow through the arc when grounding. If we define the level of regulation of single-phase earth faults and over voltages as

$$K = \frac{I_c}{I_i} = \frac{1}{\omega^2 L_c 3C_f} = \frac{\omega_0^2}{\omega^2} \quad (1)$$

(I_{cu} is the current passing through the winding, I_{ca} is the capacitance current), then the difference from the exact regulation can be defined as

$$\nu = 1 - K = 1 - \frac{\omega_0^2}{\omega^2} \quad (2)$$

Thus, the value of the residual current passing through the arc will be determined by the

$$I_r = \sqrt{I_a^2 + (I_{cu}\nu)^2} \quad (3)$$

expression.

2. MATERIALS AND METHODS

The solution of the problem: The arc will be extinguished when the residual current I_r crosses zero. After that, the potential of point "1" (Fig. 1) will change in accordance with the frequency ω of the operating current of the network, and the potential of point "2" will change in accordance with the special frequency ω_0 C_f - L_c circuit "3". In the case of an ideal setting (at $\nu = 0$), the voltage recovery in the arc gap (potential difference between points 1 and 2) will depend on the extinction of free oscillations in the $3C_f$ - L_c circuit and will proceed at a very low speed. As a result, it will be easier to restore the dielectric strength in the arc gap and extinguish the arc.

When the difference from fine control is within $\nu = +5\%$, the voltage recovery rate differs little from the case of fine control. For large values of " ν ", the value of the restored voltage may be higher than the phase voltage. Thus, for reliable arc quenching, the adjustment must be as accurate as possible. This reduces both the residual current cost and the rate of voltage recovery [4,5].

With fine adjustment of the arc chute, a reliable arc extinguishing of a single-phase earth fault is ensured in all cases. However, at this time, there is a large displacement of the neutral of the network and, as a result, the generation of extreme voltages in the phases, and this situation also occurs even with a very slight displacement of the neutral in the network [6].

The mentioned situation is explained on the basis of the replacement scheme shown in (Fig. 2). In an isolated network with a neutral, the arcing coil is connected in series to the sum of the capacitances and currents of the network, and a bias voltage U_0 of the network neutral is applied to this circuit. Thus, the circuit in (Fig. 2) allows the presence of a resonant circuit, while a significant increase in voltage in individual elements of the circuit is possible.

Voltage on isolated network neutral

$$U_0 = \frac{U_1 y_1 + U_2 y_2 + U_3 y_3}{y_1 + y_2 + y_3} \quad (4)$$

where $U_1=U_f$; $U_2=a^2 U_f$; $U_3=a U_f$;

$$a = -\frac{1}{2} + j \frac{\sqrt{3}}{2};$$

j_1, j_2, j_3 - electrical conductivity of the phases separately with respect to the ground.

The active conductivity coefficient is determined by the leakage current on the surface of the insulators and can be neglected. Normally, even when the wires in the line are horizontal, the capacitances of the phases with respect to earth are not equal. With a horizontal arrangement of wires, the power of the middle phase is 10% less than that of the extreme phases. Thus, if we take $C_1=C_3=C_f$ and $C_2=0.9C_f$, according to expression (4) we get: $U_0=0.035U_f$ [7].

According to the design scheme in (Fig. 2), the neutral bias voltage will be determined by the voltage on the arc quenching coil. Coil voltage

$$U_c = U_0 \frac{r_c + j\omega L_c}{\frac{1}{j3\omega C_f} + r_0 + j\omega L_c} = U_0 \frac{j r_c 3\omega C_f - \omega^2 L_c 3C_f}{1 + j r_c 3\omega C_f - \omega^2 L_c 3C_f}$$

where,

$$\omega_0 = \frac{1}{\sqrt{L_c 3C_f}}; \quad K = \frac{\omega_0^2}{\omega^2}; \quad \delta = r_c 3\omega C_f \quad (5)$$

$$U_c = U_0 \frac{1 - jk\delta}{1 - k - jk\delta} \quad (5)$$

$1 - K = u$ and thus

$$U_c = U_0 \frac{1}{\sqrt{V^2 + (K\delta)}} - j \frac{K\delta}{\sqrt{V^2 + (K\delta)}} \quad (6)$$

(Fig. 3) shows the dependences of the network bias voltage - the attenuation coefficient U_c on the degree of different adjustment. As can be seen from the dependencies and expression (6), $U_0 = 0.035U_f$, and the neutral displacement voltage reaches $U_c=0.7U_f$ for the case $\delta=0.05$. Thus, the voltage in one of the phases is reduced to $0.3U_f$, and in the phases it increases to $1.5U_f$. Under such conditions, losses increase, insulation wear accelerates, and the harmful effect on communication lines increases [8].

As a result of reducing the correction factor, the neutral offset is also slightly reduced. However, in this case, the state of extinguishing the arc caused by a single-phase earth fault is degraded.

In the case of full regulation of the arcing winding ($K=1$; $u=0$) from a single-phase grounding arc (according to the replacement circuit in (Fig. 1), the active current is small and equal to $I_r=U_f \cdot q_c$, called residual current, will flow. The moment the current crosses zero, the arc is extinguished. After the arc is extinguished, the restoring voltage in the arc gap will be determined by the potential difference of points 1 and 2 (Fig. 1). where the potential of point 1 will change in accordance with the operating frequency of the energy source, and the potential of point 2 will change in accordance with the special frequency ω_0 of the " $3C_f - L_c$ " circuit. As a result, the restored voltage in the span of the arc will change accordingly in expression (7) [9,10].

$$U_b(t) = U f_m \left\{ \cos(\omega t + \varphi) - e^{-\delta t} \left[\cos(\omega_k t + \varphi) \right] \right\} \quad (7)$$

where φ is the phase angle of the voltage at the moment the current crosses zero, determined by the conductivity qc.

$\delta = \frac{q_c}{2c}$ – vibration damping coefficient ($C=3C_f$); $k=1-\nu$, $\varphi=0$. Thus, expression (7) can be written as follows.

$$U_b(t) = U_{fm} \left\{ \cos \omega t - e^{-\delta t} \cos[\omega t(1-V)] \right\} \quad (7')$$

According to expression (7)', the adjustment error decreases when the voltage is restored to U_{fm} with an increase in u and, accordingly, increases at the maximum voltage value - $U_b(t)$ - in the arc gap. Thus, it is necessary to try to adjust the arc quenching coil according to the condition of full resonance. However, in practice this is not possible. Because the value of capacitive currents often changes and cannot be correctly calculated, and the adjustment of the winding is done in steps, and not regularly.

On the other hand, to reduce the neutral bias voltage, it is necessary to increase "u", but expression (7) shows that this is undesirable.

To reduce the neutral-to-neutral bias voltage, a resistive resistor can be connected in series with the arc winding. However, the report shows that due to the increased damping of oscillations in this case, the voltage recovery rate in the arc span increases [11,12].

As can be seen from the equations, capacitive currents with single-phase grounding cause a number of shortcomings in the operation of networks (10÷35) kV, compensated by an inductive winding. However, the intensive expansion of networks (10÷35) kV recently increases the relevance of this issue.

The design scheme for the analysis of a single-phase earth fault is shown in (Fig. 4). In this case, all the initial elements of the three-phase circuit are assumed to be linear. In this case, the calculation is solved by the method of symmetrical connections

If the resistance r_n is connected to the network neutral, the arc resistance r_q can be neglected. Thus, taking the positive and negative sequence resistances $Z_1=Z_2$, the currents and voltages in

the steady state with a single-phase earth fault will be calculated using the following expressions [13].

$$I_a^1 = \frac{3U_a}{2Z_1 + Z_0 + 3r_n} = \frac{3Z_1}{2Z_1 + Z_0 + 3r_n} I^{(3)} \quad (8)$$

where Z_0 is the resistance of the zero-sequence circuit,

$$I^{(3)} = \frac{U_a}{Z_1} - \text{fixed values of the three-phase short-circuit current connected to earth}$$

$$I_b^{(1)} = 0; \quad I_c^{(1)} = 0.$$

Steady-state voltage on the network neutral

$$U_n = U_a \frac{Z_0 - Z_1 + 3r_n}{2Z_1 + Z_0 + 3r_n}, \quad (9)$$

Fixed voltages in phases: $U_{aq}=U_a-U_n$; $U_{bq}=U_b-U_n$; $U_{cq}=U_c-U_n$.

For given fixed values of current and voltage of a single-phase earth fault, $Z_1=jx_1$; $Z_2=jx_2$; $Z_0=r_0+jx_0$ are accepted, that is, capacitive resistances are not taken into account according to the replacement scheme (Fig. 4) [14].

Now let's analyze the possibility of using a structure not made of metal wire with inductive resistance as a grounding device. For this, it is proposed to use electrical concrete with electrical conductivity. Electrical concrete differs from the concrete used in construction in its composition and is used as an electrical material without inductance. Such a material must have sufficient electrical strength, withstand heating, and at the same time have the necessary electrical conductivity and provide mechanical strength [15].

As a conductive phase, processed coal waste and the remains of graphite electrodes of steel-smelting electric furnaces are used. Cement is used as a binder.

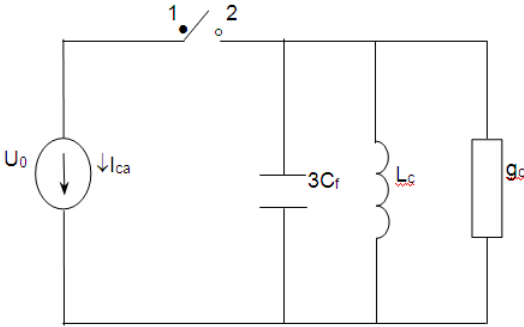

Fig. 1. Scheme for analyzing the current passing through the arc

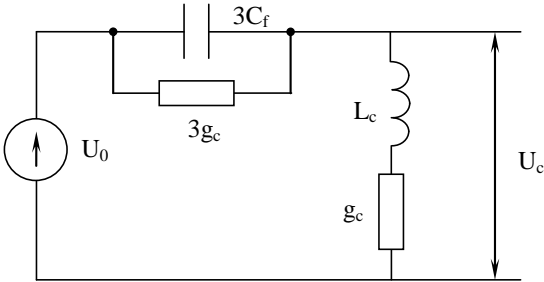

Fig. 2. Calculation diagram of the voltage in the arc quenching coil during normal operation

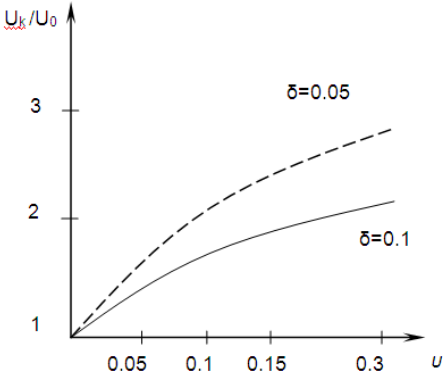

Fig. 3. The dependence of the bias voltage on the degree of regulation

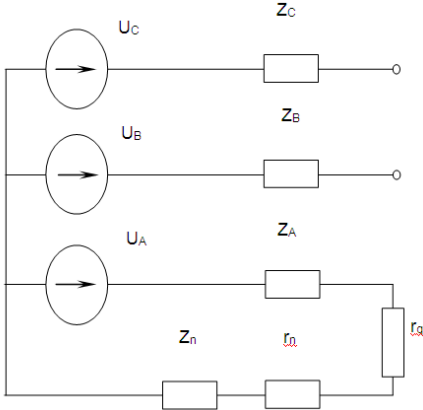

Fig. 4. Calculation diagram of a single-phase earthing switch with neutral grounding with r_n resistance

3. RESULTS

As a result of the study, we can come to the following conclusion:

- In recent years, the expansion of networks (10÷35) kV, as a rule, is carried out by cable lines. Single-phase earth faults caused by atmospheric surges are usually conductive. However, single-phase earth faults caused by cable insulation punctures are not transient. Therefore, in case of single-phase short circuits in cables, damage and failure of the insulation drastically reduce the efficiency of arc extinguishing devices;
- With a stable earth fault of one phase, the insulation of the other two phases remains under the influence of an overvoltage equal to the mains voltage for a long time. This, in turn, increases the possibility of two- or three-phase short circuits, as well as a sharp acceleration of the aging process of cable lines;
- In connection with the expansion of networks, the price of single-phase earth fault currents increases, and as a result, the price of the uncompensated high-frequency component of the current increases, and it becomes difficult to extinguish the arc;
- In compensated networks, it is necessary to take additional measures to limit the neutral displacement, which complicates the operation of the network.

In connection with the above, by carrying out accurate calculations, it is necessary to solve a number of issues on grounding the neutral with active resistance in networks (10÷35) kV: effective grounding of networks, ensuring safety, limiting the impact on communication lines, limitation of emerging surges, ensuring normal operation of switching devices, etc.

4. CONCLUSION

1. Due to the difficulty of obtaining an accurate adjustment when earthing the neutral through an arcing coil, and even under normal conditions, overvoltages in the phases are likely as a result of the displacement of the neutral.

2. Networks with zero insulation (10÷35) kV have disadvantages that adversely affect the insulation of operating equipment, and in modern conditions it is desirable to improve the operating modes of such networks.
3. In networks with an isolated neutral (10÷35) kV, the connection of the neutral to earth with active resistance allows you to significantly limit the extreme voltages that may occur in the network.

COMPETING INTERESTS

Authors have declared that no competing interests exist.

REFERENCES

1. Vainshtein R.A. Modes of neutral grounding in electrical systems: Textbook / R.A. Weinstein, N.V. Kolomiets, V.V. Shestakova. - Tomsk: TPU Publishing House. 2006;118.
2. Vishtibeev AV, Kadomskaya KP. On resistive neutral grounding in 6-35 kV networks. *Energetik*. 2001;(3):33-34. UDC 62-50:519.216
3. Shuin VA, Gusenkov AV. Protected against earth faults in electrical networks 6-10 kV. - M.: NTF Energoprogress. 2001;104:3.
4. Shalin AI. Relay protection against earth faults in 6.35 kV networks with resistive neutral grounding // Neutral grounding modes of 3-6-10-35 kV networks: Reports of the scientific and technical conference. - Novosibirsk: GTsRO. 2004;160-167.
5. Bouziane B, Elmaouhab A, et al. Smart grid reliability using reliable block diagram case study: Adrar's isolated network of algeria // 2019 international conference on power generation systems and renewable energy technologies (PGSRET): Proc. Istanbul, Turkey. – IEEE; 2019.
6. Sestasombut P, Ngaopitakkul A. Evaluation of a direct lightning strike to the 24 kV distribution lines in Thailand. *Energies*. 2019;12(16):3193. DOI: <https://doi.org/10.3390/en12163193>
7. IEEE Std 81-2012 guide for measuring earth resistivity, ground impedance and earth surface potentials of a grounding system. New York, IEEE. 2012;86. DOI: 10.1109/ieeestd.2012.6392181

8. Rudenko SS, Koliushko DG, Kashcheyev OV. Determination of direction to reconstruction of rounding system. *Electrical Engineering and Electromechanics. (Ukr)*. 2017;(2):57-61. DOI: 10.20998/2074-272X.2017.2.09
9. Glebov OYU, Koliushko DG, Koliushko GM, Ereemeeva EP. On the issue of design of grounding systems of 330 (220) kV substations to ensure the electromagnetic compatibility of secondary circuits. *Electrical Engineering and Electromechanics*. 2018;(5):72-79. DOI: 10.20998/2074-272X.2018.5.11
10. Hossain MS, Ahmed R, Hossain S. Design and optimization of substation grounding grid for ensuring the safety of personnel and equipment. *Journal of Electrical Power and Energy Systems*. 2021;5(1):71-80. DOI:https://doi.org/10.26855/jepes.2021.08.001
11. Sivokobylenko VF, Dergilev MP. Neutral operating modes of distribution networks 6-10 kV. *Sat. scientific works of DonSTU. Series: Electrical engineering and energy*. vol. 67: - Donetsk: DonNTU, 2003. pp. 49 - 58. DSTU (GOST). 2006;7(1).
12. Tsapenko EF. *Earth faults in 6-35 kV networks*. - M.: Energoatomizdat. 1986. – 128.
13. Koliushko DG, Rudenko SS. Determination the electrical potential of a created grounding device in a three-layer ground. *Technical Electrodynamics*. 2018(4):19-24. DOI:https://doi.org/10.15407/techned2018.04.019
14. Koliushko DG, Rudenko SS. Experimental substantiation of the calculation procedure of normalized parameters of grounding device based on the three-layer soil model. *Electrical Engineering and Electromechanics*. 2018(1):66-70. DOI:https://doi.org/10.20998/2074-272X.2018.1.11
15. Li Y, Wong CP. Recent advances of conductive adhesives as a lead-free alternative in electronic packaging: Materials, processing, reliability and applications. *Materials Science and Engineering: R: Reports*. 2006 Jan 30;51(1-3):1-35.

© 2023 Rzayeva et al.; This is an Open Access article distributed under the terms of the Creative Commons Attribution License (<http://creativecommons.org/licenses/by/4.0>), which permits unrestricted use, distribution, and reproduction in any medium, provided the original work is properly cited.

Peer-review history:
The peer review history for this paper can be accessed here:
<https://www.sdiarticle5.com/review-history/94649>